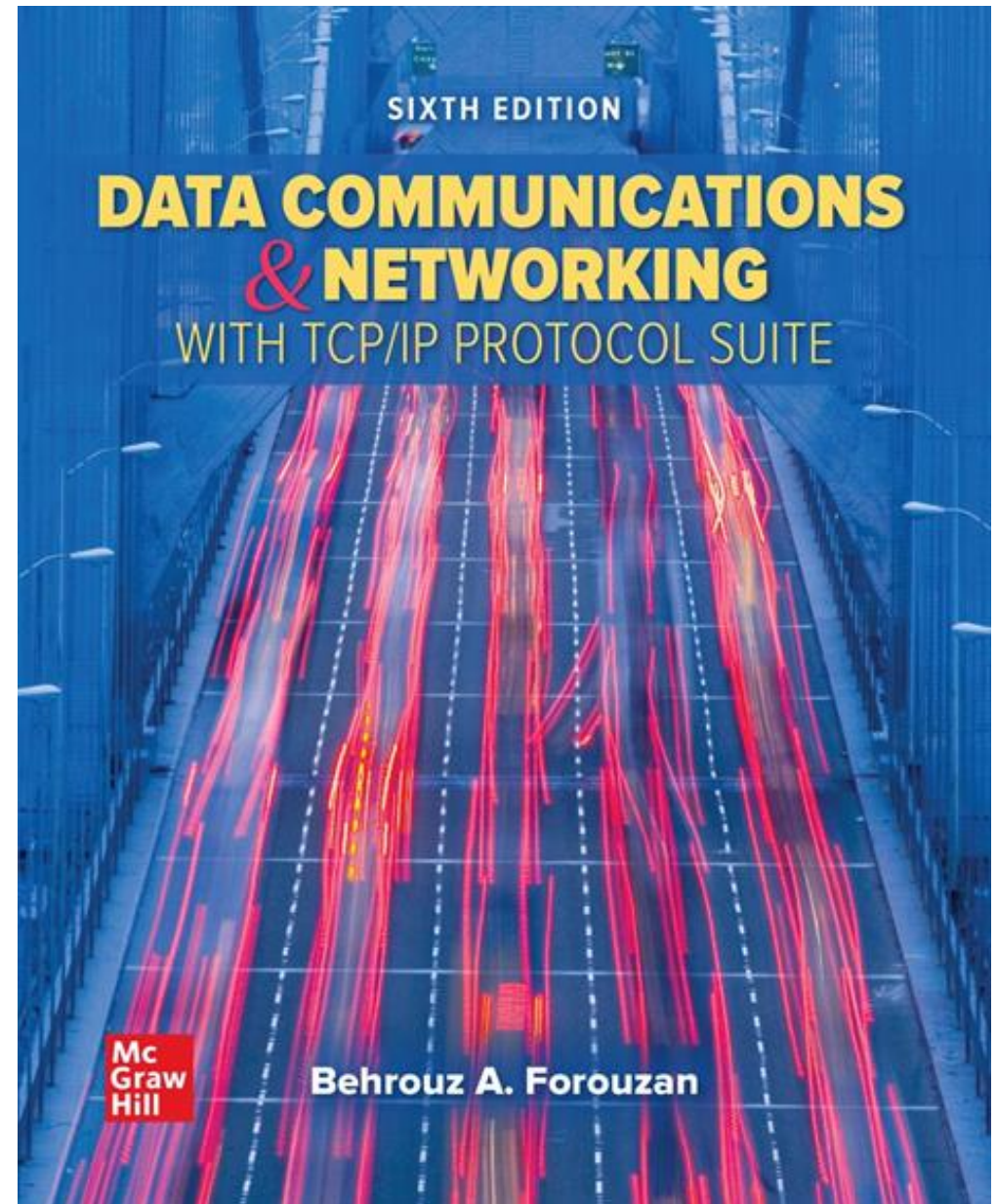


Chapter 06

Connecting Devices And Virtual LANs

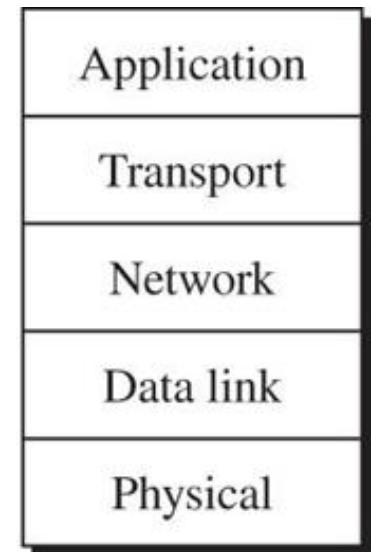
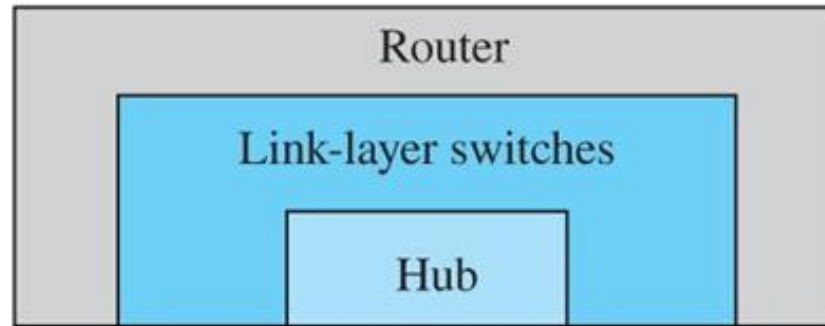
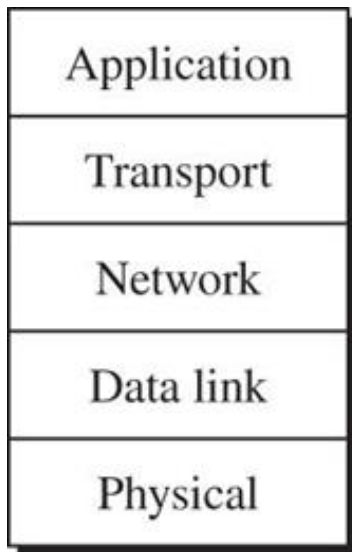
- Data Communications and Networking, With TCP/IP protocol suite Sixth Edition
- Behrouz A. Forouzan



6-1 CONNECTING DEVICES

- Hosts and networks do not normally operate in isolation. We use connecting devices to connect hosts together to make a network or to connect networks together to make an internet. Connecting devices can operate in different layers of the Internet model. We discuss three kinds of connecting devices: hubs, link-layer switches, and routers.

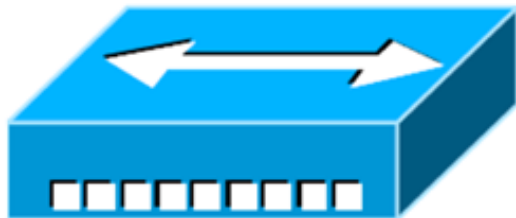
Figure 6.1 Three categories of connecting devices



- Access the text alternative for slide images.

Hubs

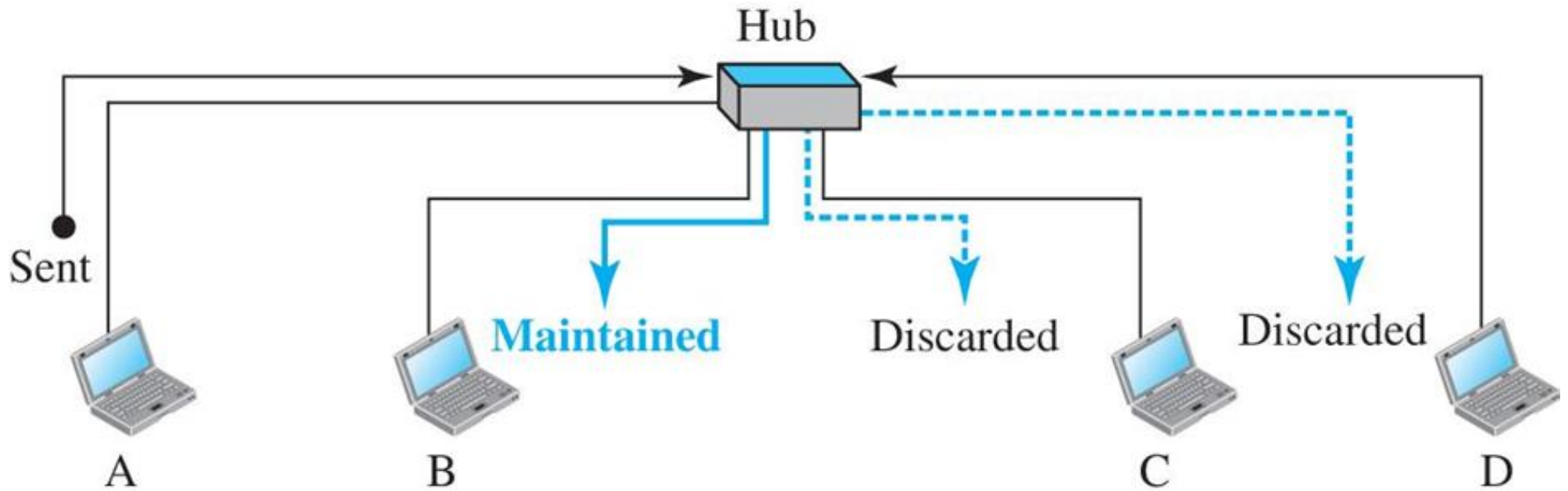
- **Hub is a physical layer device**
- Operate on bits rather than frames
- Used to connect stations adapters in a **physical** star topology but **logically** bus
- Connection to the hub consists of **two pairs of twisted pair wire** one for **transmission** and the other for **receiving**.
- Hub receives a bit from an adapter and sends it to **all** the other adapters without implementing any access method.
- Does not do **filtering** (Filtering means the device can check the destination link-layer address of a frame and can decide from which outgoing port the frame should be sent)
- Hubs just copy the received bits onto **all other links**
- Multiple Hubs can be used **to extend** the network length
- For star topology, the maximum length of the connection between a host NIC and the central device is 100 meters □ the maximum length between any two nodes is 200 m = maximum network length



Hub



Figure 6.2 A hub

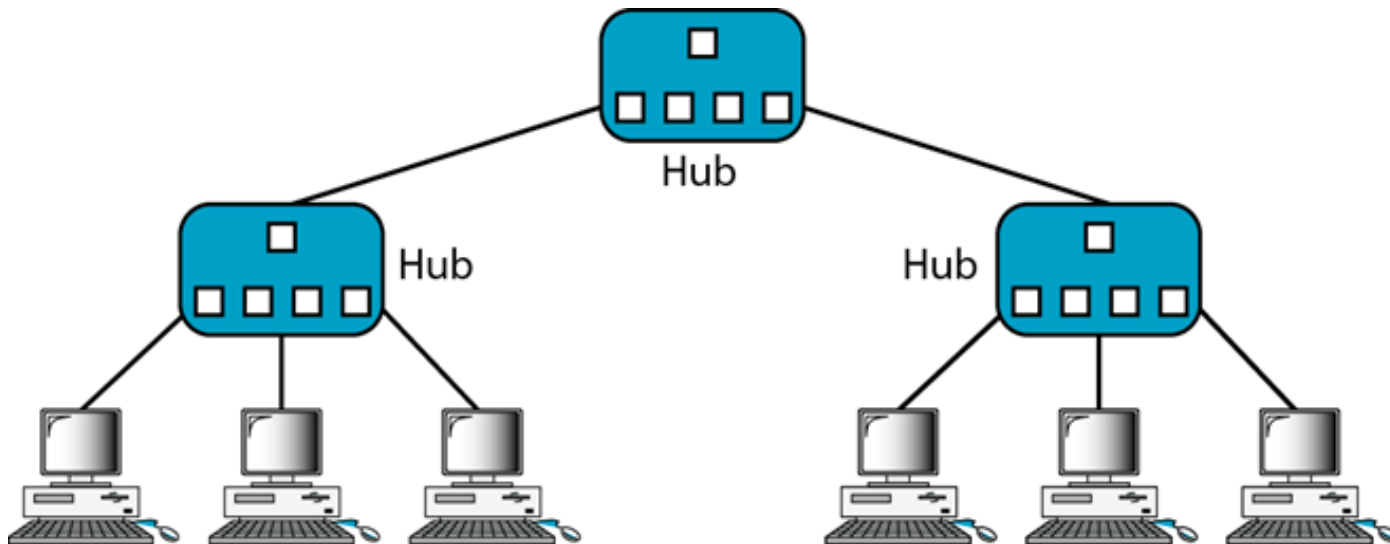


Hubs

- The entire hub forms **a single collision domain**, and **a single Broadcast domain**
 - **Collision domain:** Collision Domain
Definition: is that part of the network (set of devices) when two or more nodes transmit at the same time collision will happen.
 - **Broadcast domain:** Broadcast domain
Definition: is that part of the network (set of devices) where each device can receive other devices broadcast messages

Interconnecting with hubs

- hub interconnects LAN segments
- **Advantage:**
 - Extends max distance between nodes
- **Disadvantages**
 - Individual segment collision domains become one large collision domain □ **(reduce the performance)**

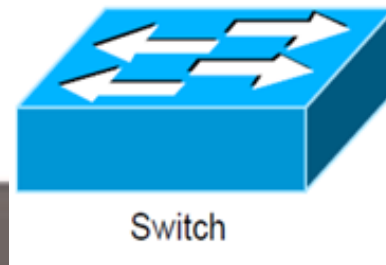


Here we have a single **collision** domain and a single **broadcast** domain

Link-Layer Switches

A link-layer switch (or switch) is a data link layer device. The switch physical-layer, regenerates the signal it receives.

As a Data link layer device, the link-layer switch can check the MAC addresses (source and destination) contained in the frame.



Multilayer
Switch

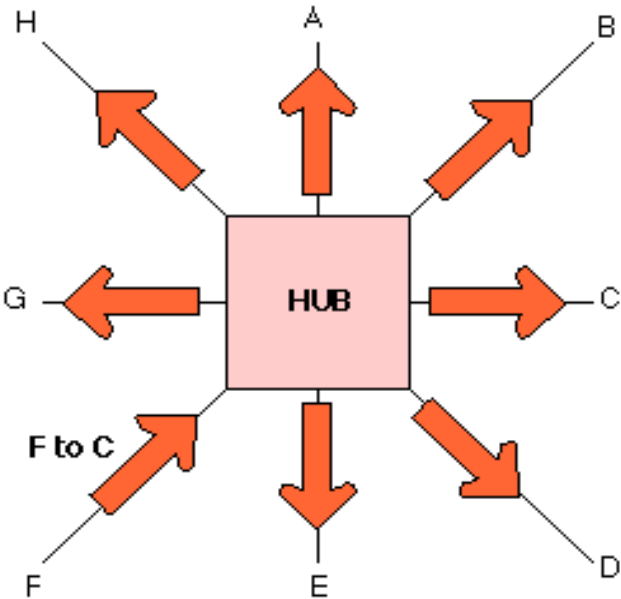


switches

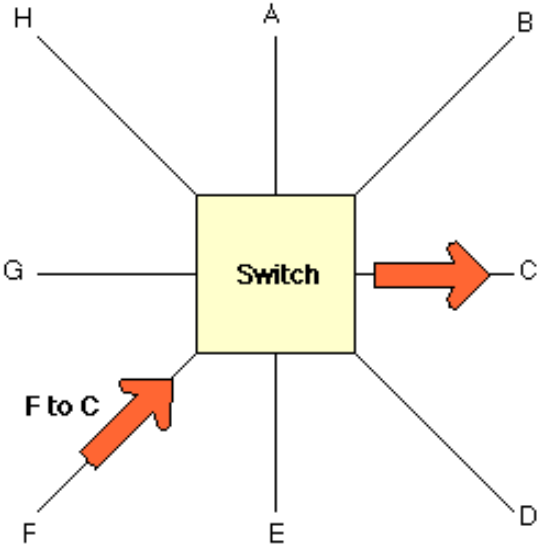
- Data link layer device.
- Deals with Frames
- Used to **divide** (segment) the LAN into smaller LANs segments
- In case of bus topology or star with Hub, Switch runs CSMA/CD before sending a frame onto the link not like the hub
- This means each connection to the switch port is separate collision domain.
- Switch does not send the received frame to all other interfaces like hubs , but it performs **filtering** which means:
 - Switch forwards the frame through certain port based on its destination MAC address that leads to the destination
 - This is done by a Switch table (**forwarding table**) that contains entries for the hosts on the LAN
 - The Switch table is **initially empty** and **filled automatically** by **learning from frames movements** in the network
 - An entry in the switch table consists of : host LAN (**MAC Address, Switch Interface to which the node is connected to, the record creation time**)

Address	Interface	Time
62-FE-F7-11-89-A3	1	9:32
7C-BA-B2-B491-10	3	9:36
...

Switches Vs. Hubs

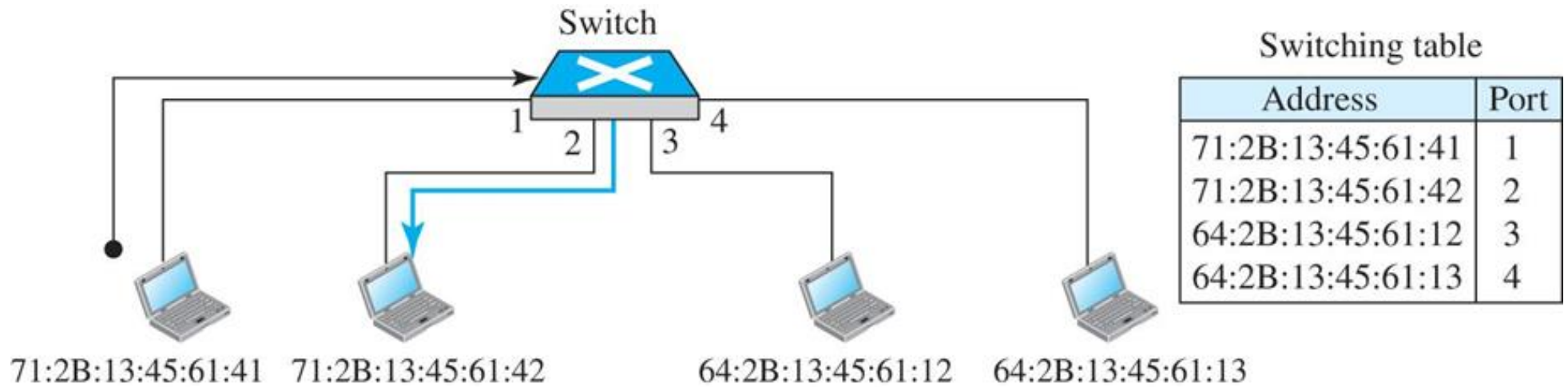


A Hub sending a packet form F to C.



A Switch sending a packet from F to C

Figure 6.3 Link-layer switch



- Access the text alternative for slide images.

Switch learning process

- **Learning Process**
- When the switch receives a frame, it compares the **source address** of the frame with each entry in the **forwarding table**
 - If **No match is found**, the switch will **add** to the table the frame **source address** and the **Interface** on which the frame was received.
 - If a **match is found**, the bridge **updates** the **Interface number** on which the frame was received if **it is different** from the one in the table also it **updates the record time**
- **Forwarding Process**
- The switch compares the **destination address** of the frame with each entry in the **forwarding table (MAC table)**
 - If a match is found then
 - The switch compares the **interface number** on which the frame was received and the interface number in the table, if they are **different** the switch **forwards** the frame through the interface number stored in the table. Otherwise, if they are the **same** the switches **discards (drops)** the frame.
 - If no match is found, the switch **floods (send through all) the frame on all interfaces** except the one on which the frame was received.
 - If the switch receives a multicast or broadcast frame, it sends it to **ALL ports**

Figure 6.4 Learning switch

Gradual building of table

Address	Port
---------	------

a. Original

Address	Port
71:2B:13:45:61:41	1

b. After A sends a frame to D

Frame will be flooded as D is not in the table

Address	Port
71:2B:13:45:61:41	1
64:2B:13:45:61:13	4

c. After D sends a frame to B

Frame will be flooded as B is not in the table

Address	Port
71:2B:13:45:61:41	1
64:2B:13:45:61:13	4
71:2B:13:45:61:42	2

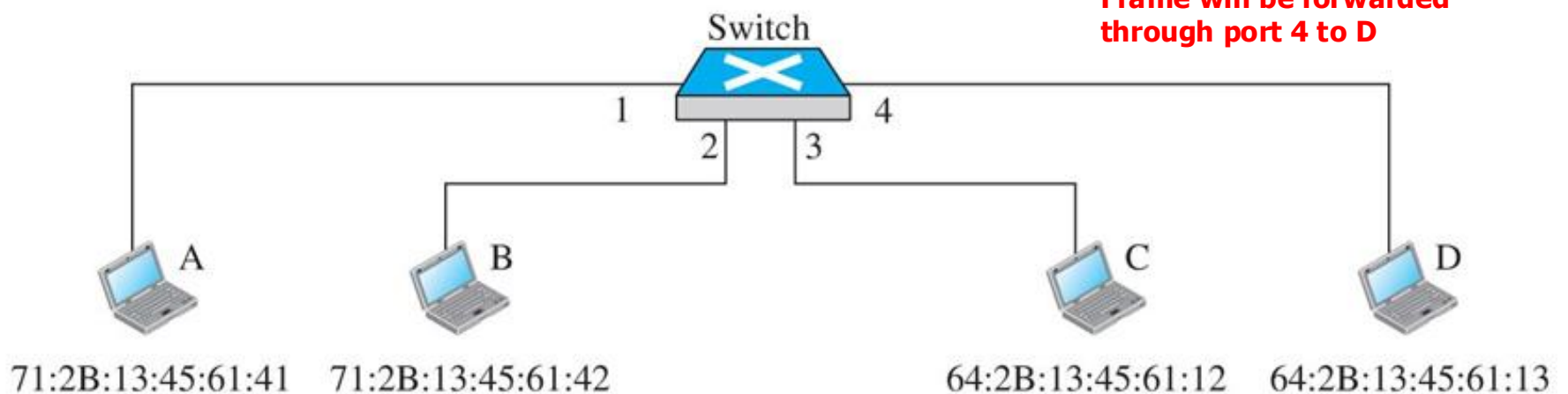
d. After B sends a frame to A

Frame will be forwarded through port 1 to A

Address	Port
71:2B:13:45:61:41	1
64:2B:13:45:61:13	4
71:2B:13:45:61:42	2
64:2B:13:45:61:12	3

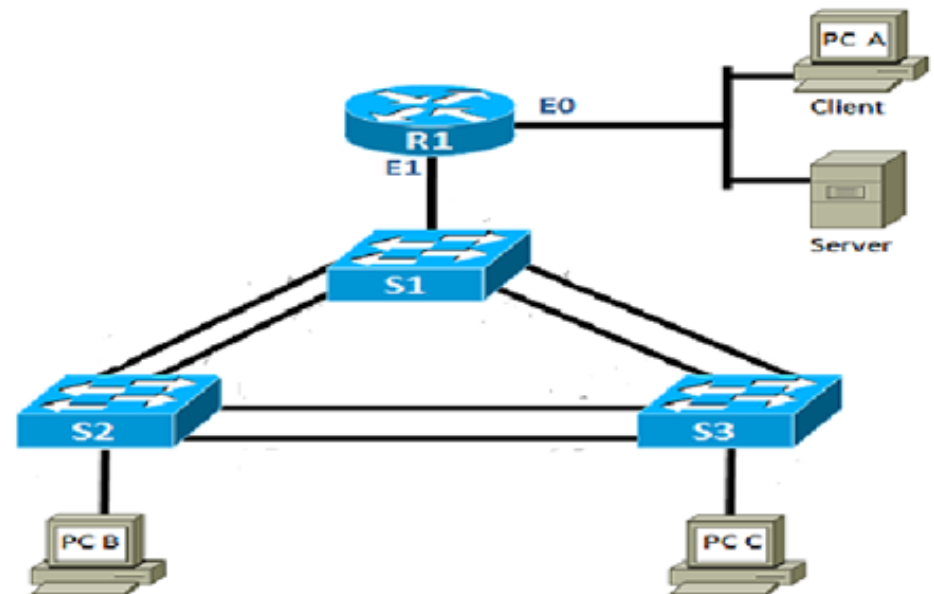
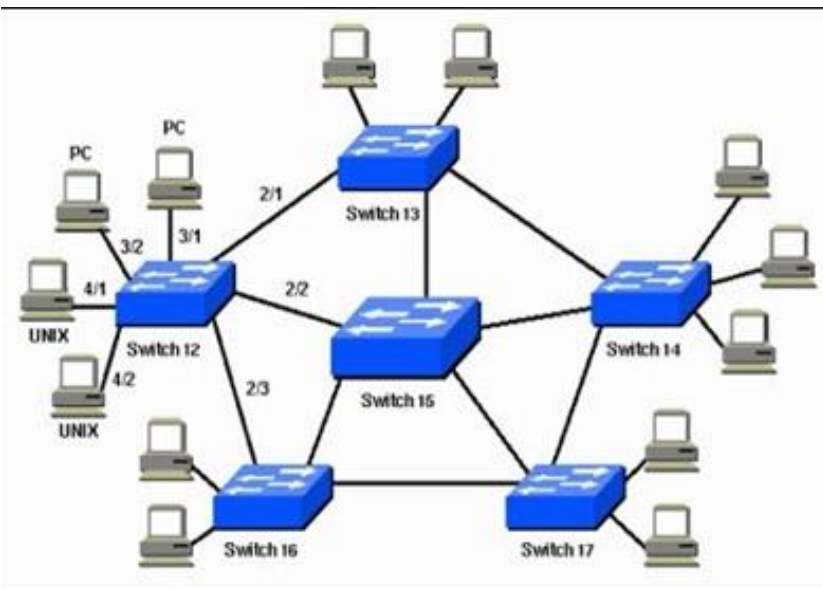
e. After C sends a frame to D

Frame will be forwarded through port 4 to D



Loop problem in a learning switch

- Switched network is a network where multiple swatches are used to connect different LAN parts.
- In order to have reliable network, multiple switches and links are used to connect different LAN parts (redundancy to increase reliability).
- This means that two host can be connected by multiple path.
- Loop problem happens when there is more than one paths between any two hosts, in a switched network.

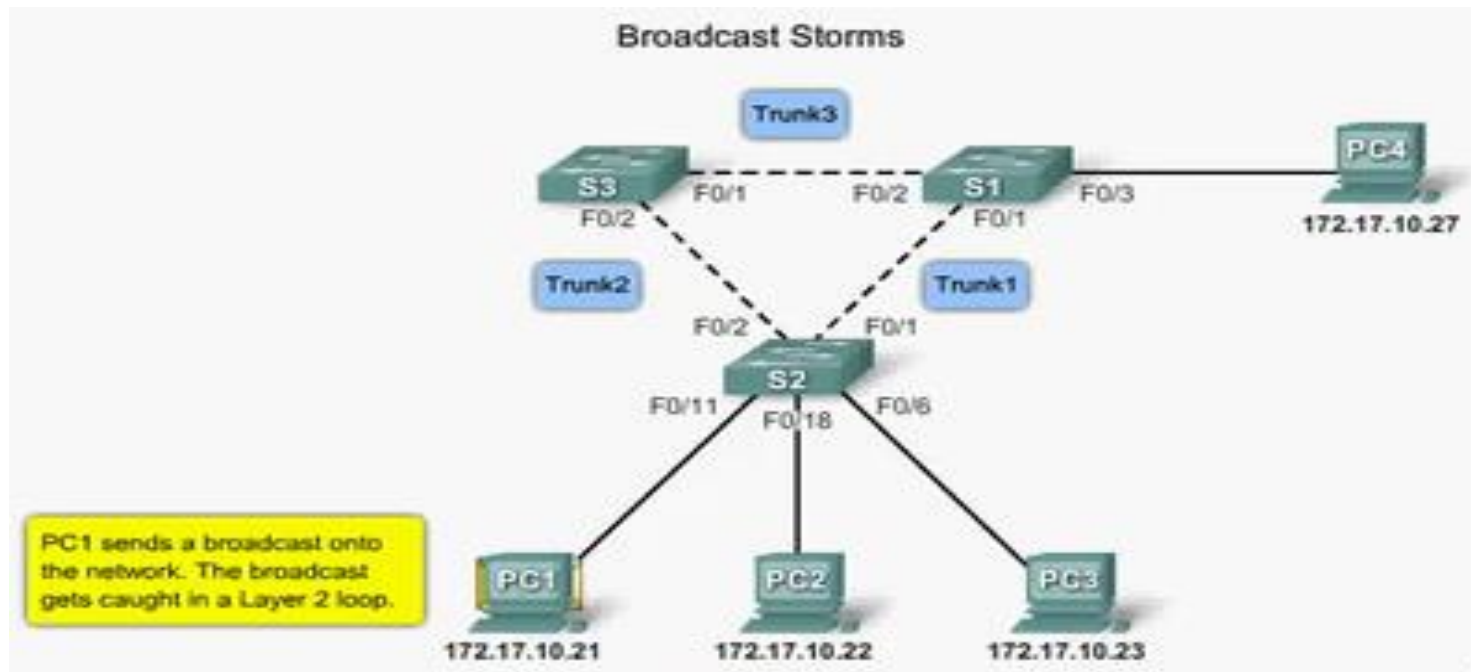


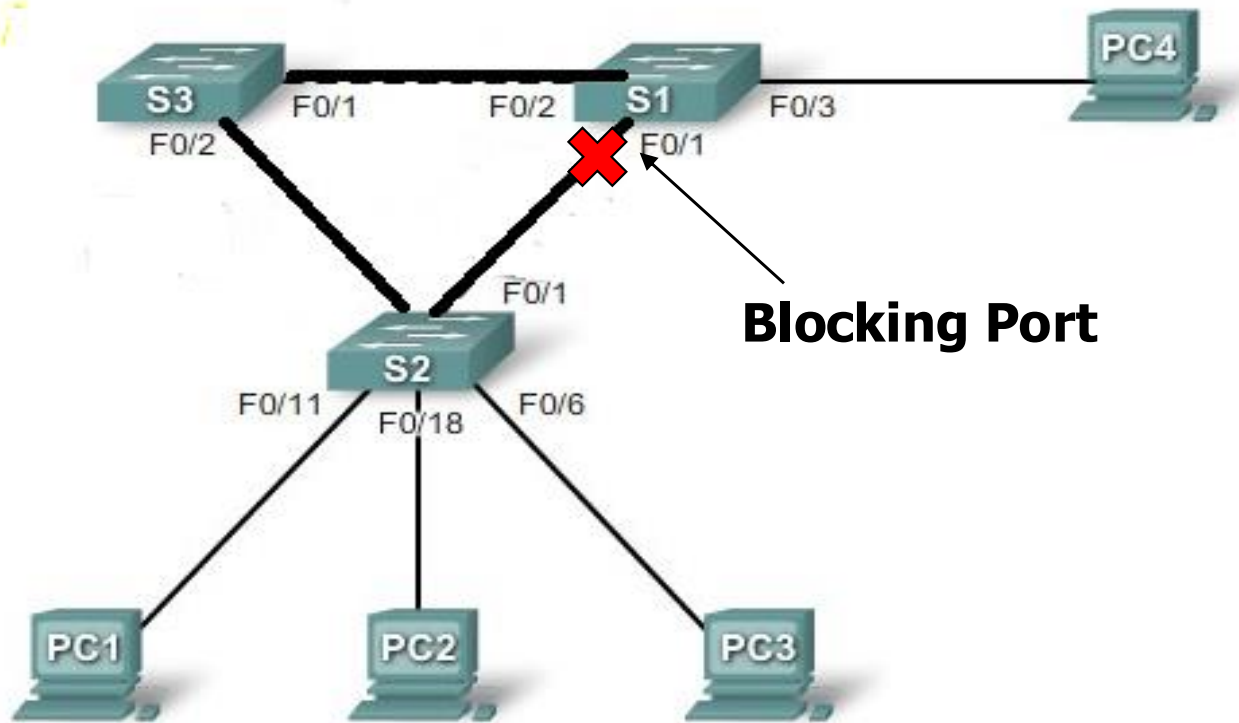
Loop problem in a learning switch

- Loops can cause broadcast storm.
- A switch will forward broadcast frame (MAC FF-FF-FF-FF-FF-FF) and Multicast frame (MAC is multicast) through all ports except the one that it came from.
- Also will do the same if the source MAC address is unicast but is not stored in the forwarding table (Unknown Unicast).
- If the network has loops, then each switch once receives broadcast, multicast, or unknown unicast will flood the frame through all other ports.
- This will replicate the same frame in the network continuously.
- This is called broadcast storm and it will consume all the network resources and then stops the network.
- Spanning tree protocol is used to eliminate the loops

Figure 6.5 Loop problem in a learning switch (Part b)

Video





- For any connected graph there is a spanning tree that maintains connectivity but contains no closed loops
- Loops are logically disabled by the spanning tree algorithm
- Some ports will be blocked by spanning tree to eliminate loops
- Blocked ports do not forward data frames but forward special frames belong to spanning tree algorithm
- Blocked ports will become forwarding port if any change happen in the network that cause spanning tree protocol to run again.

Figure 6.6 A system of connected LANs and its graph (Part a)

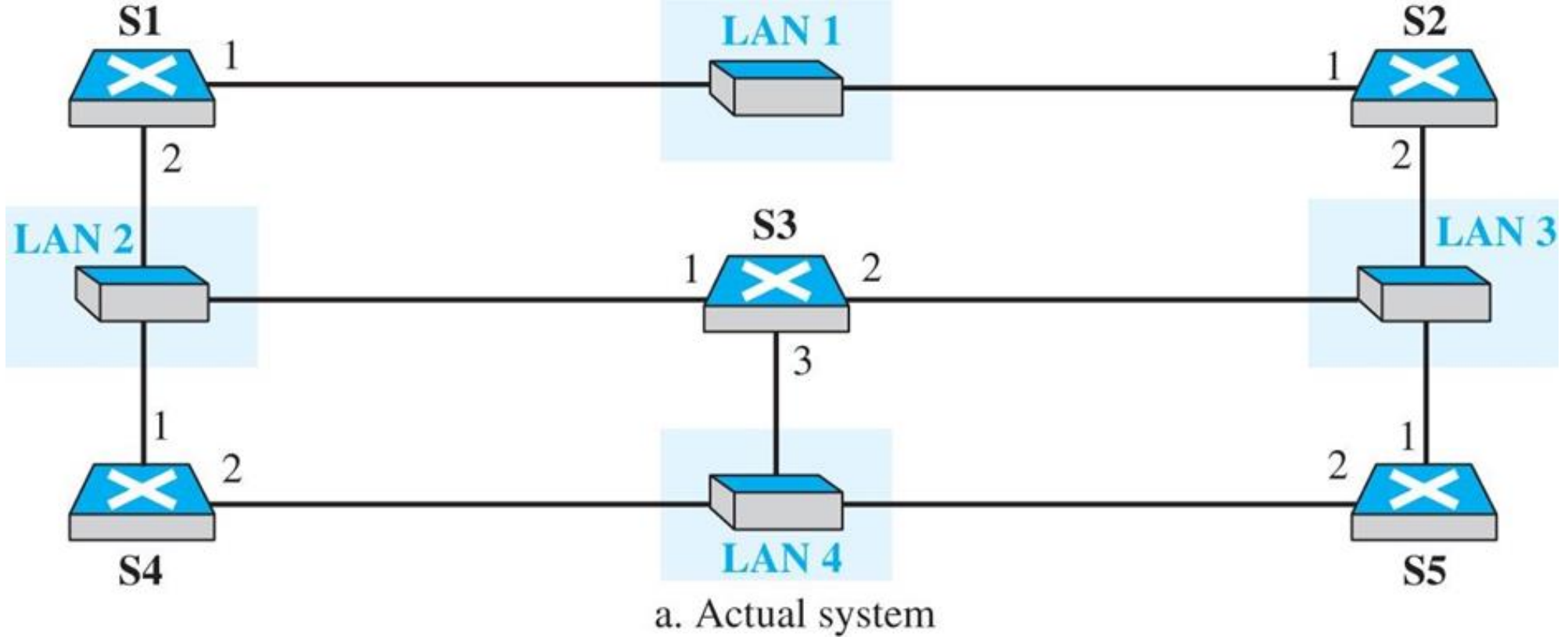


Figure 6.7 Finding the shortest path and the spanning tree for a switch.

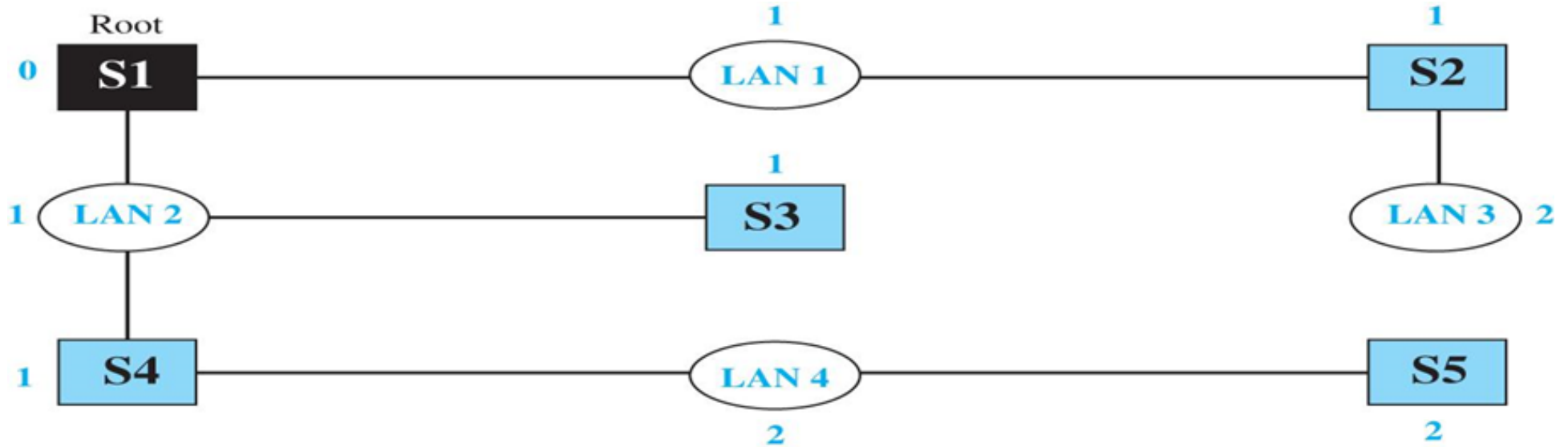
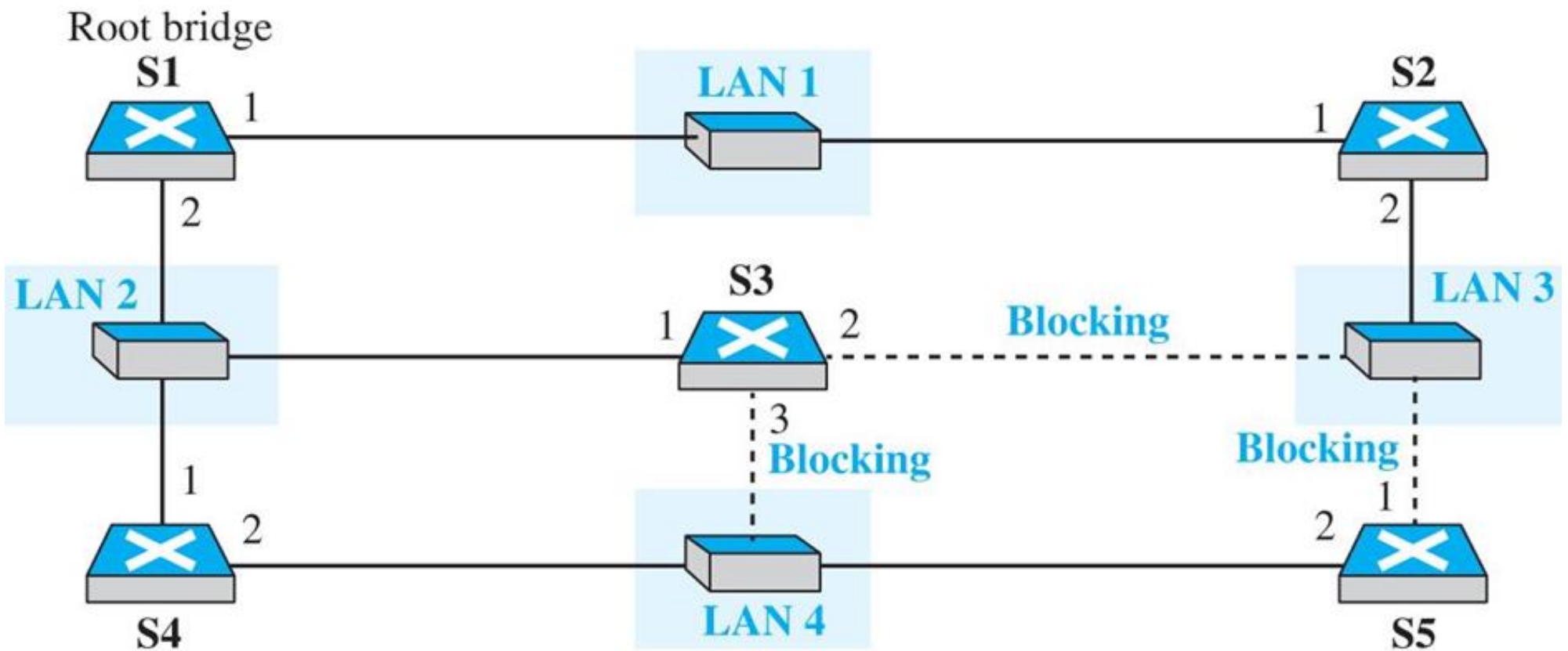


Figure 6.8 Forwarding and blocking ports after using spanning tree algorithm

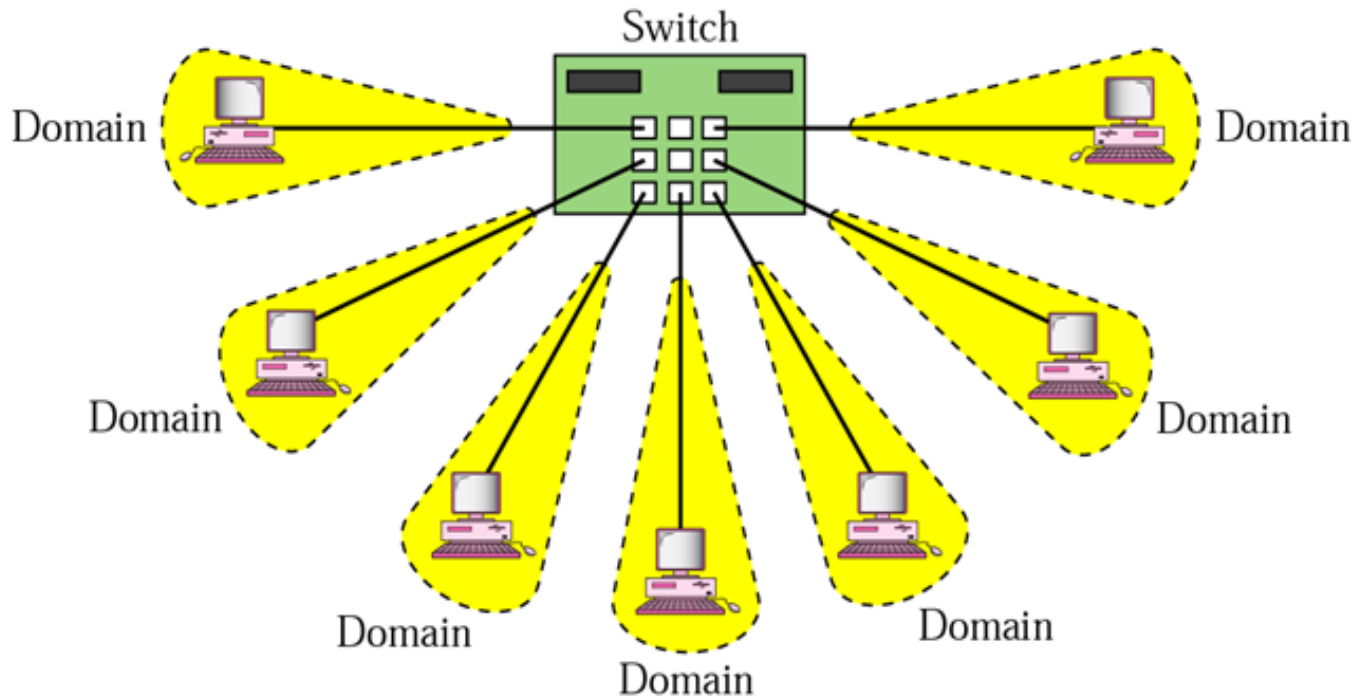
Ports 2 and 3 of bridge S3 are blocking ports (no frame is sent out of these ports).
Port 1 of bridge S5 is also a blocking port (no frame is sent out of this port).



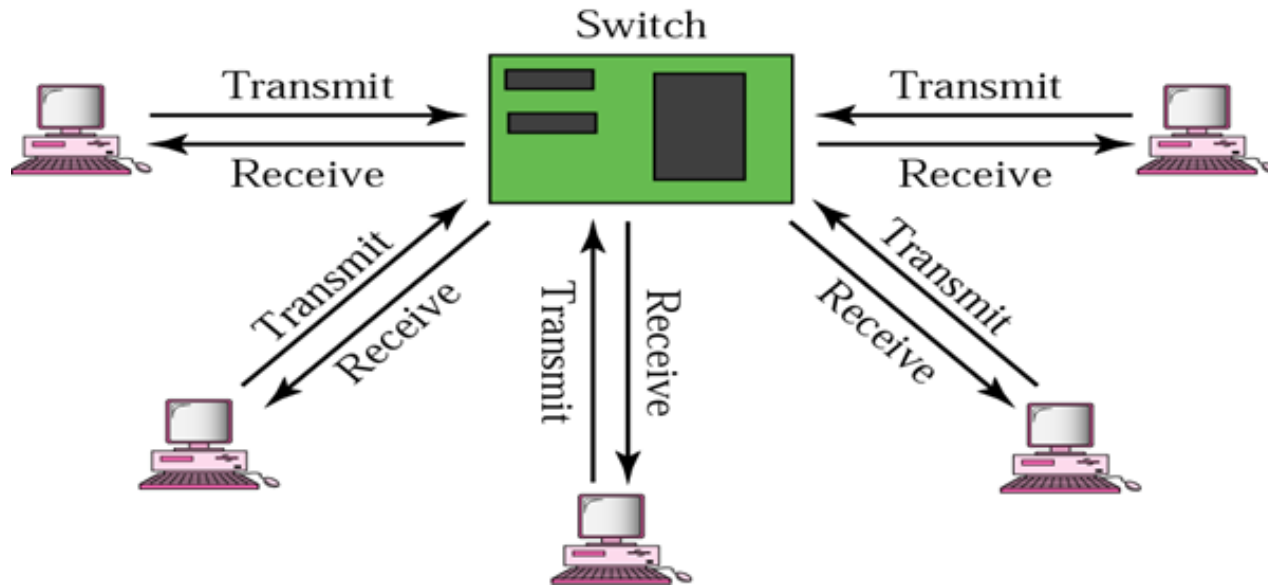
Some switch features

- Implements CSMA/CD when the medium is shared.
- switches Isolates collision domains (each LAN segment is a separate collision domain), **THIS WILL REDUCE THE POSSIBILITY OF COLLISIONS AND result in higher total max throughput (see next slide)**
- switch forwards a frame with **broadcast address** to **all** devices attached to the whole network (**single broadcast domain**)
- Increases performance and security as it isolates the traffic. Switch sends the frame through the port to which the receiving device is connected.
- Increases geographical coverage
 - No limit on the size of the LANs connected through switches
- **Transparent**: installing or removing a switch does not require the stations networking software to be reconfigured.
- (“**plug-and-play**”): *no configuration necessary* at installation of switch or when a host is removed from one of the LAN segments

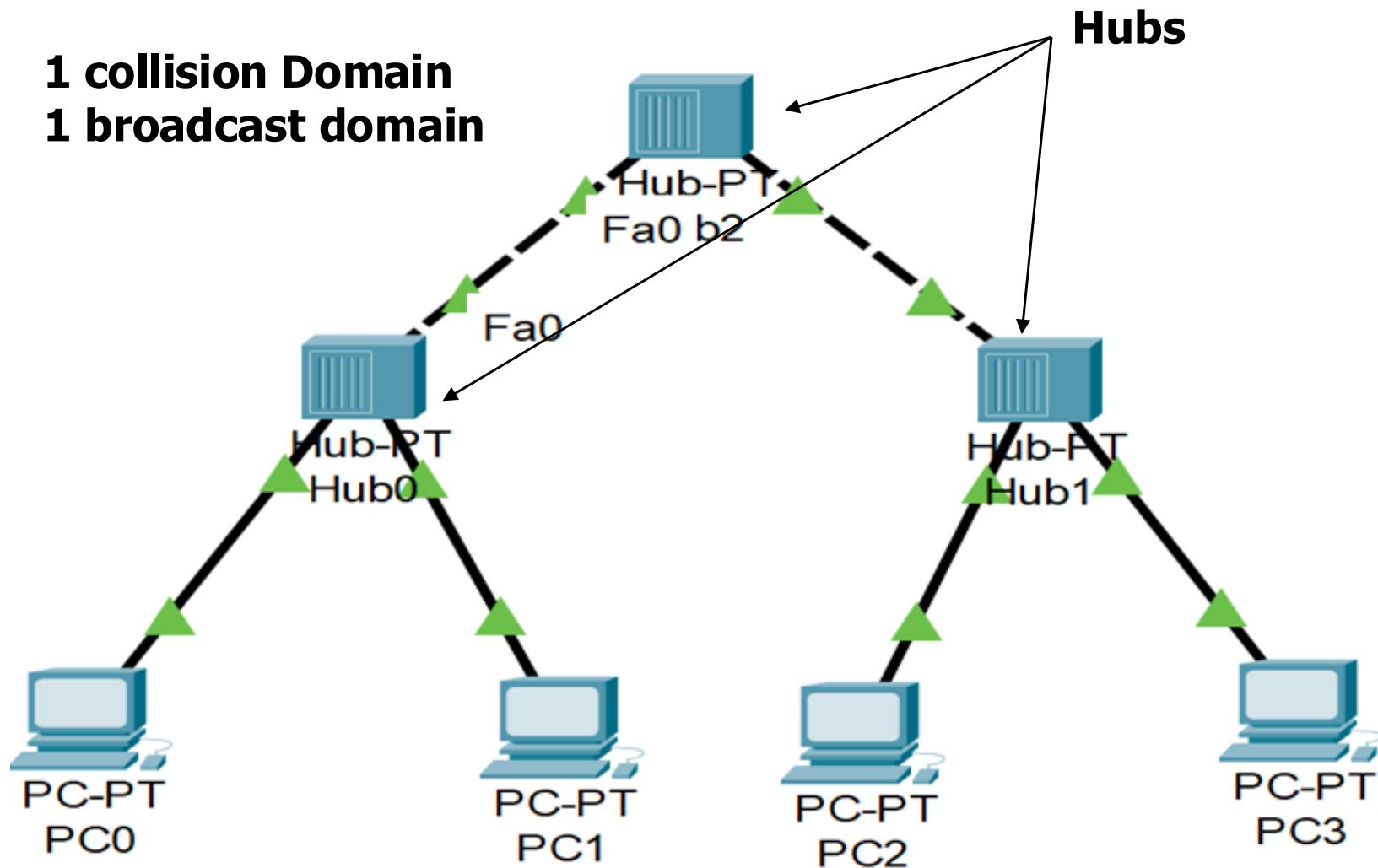
Isolated collision domains



Full-Duplex operation

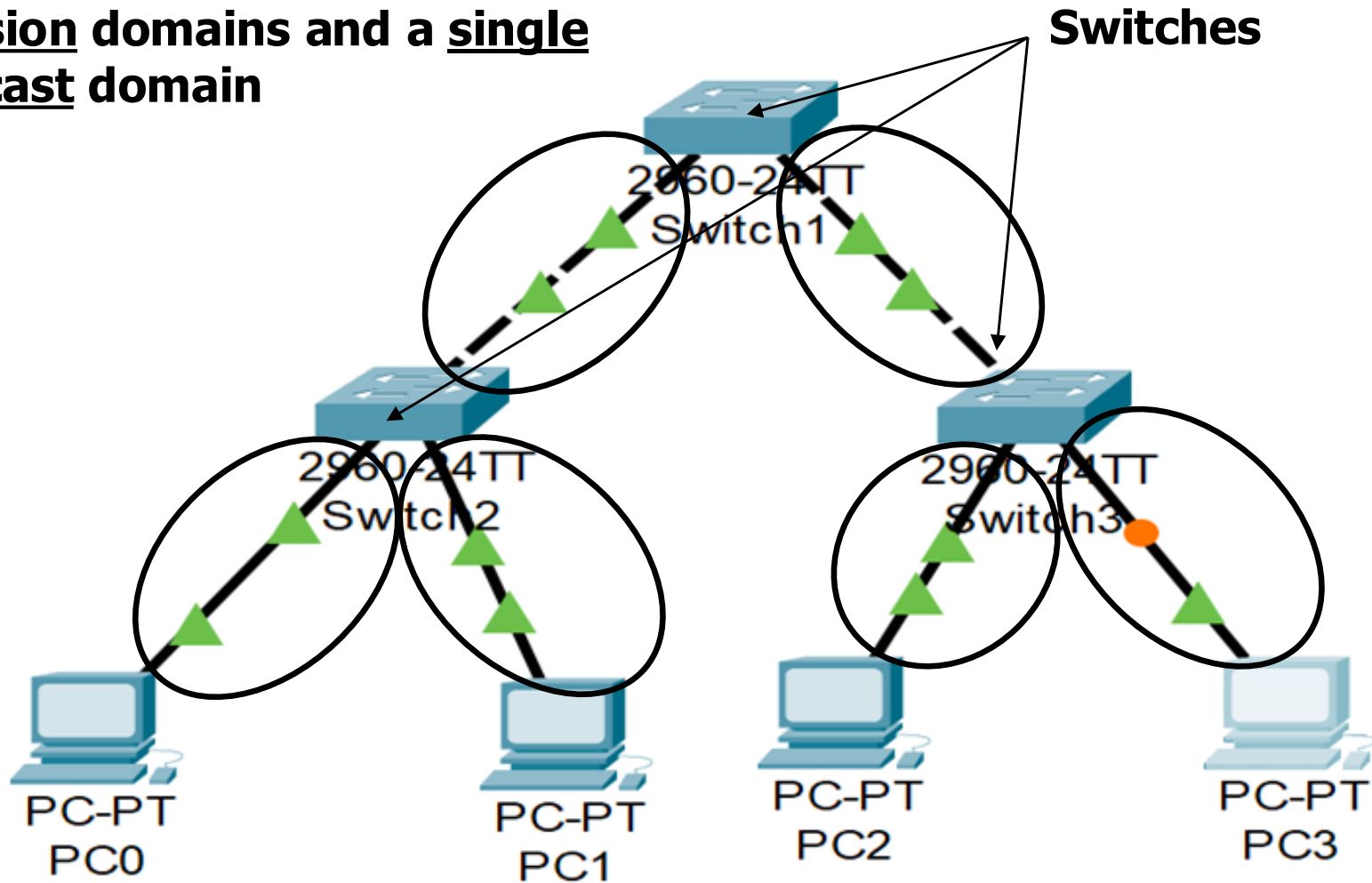


Collision domains in a nonswitched and switched network



If the bandwidth is 100Mbps, then each host has an average maximum effective bandwidth equal = $100/4$ Excluding all other devices.

6 collision domains and a single broadcast domain



If the bandwidth is 100Mbps, then each host has an average maximum effective bandwidth equal to 200 Mbps as it will work in full duplex mode. No need for CSMA/CD

Some switch features – cont'd

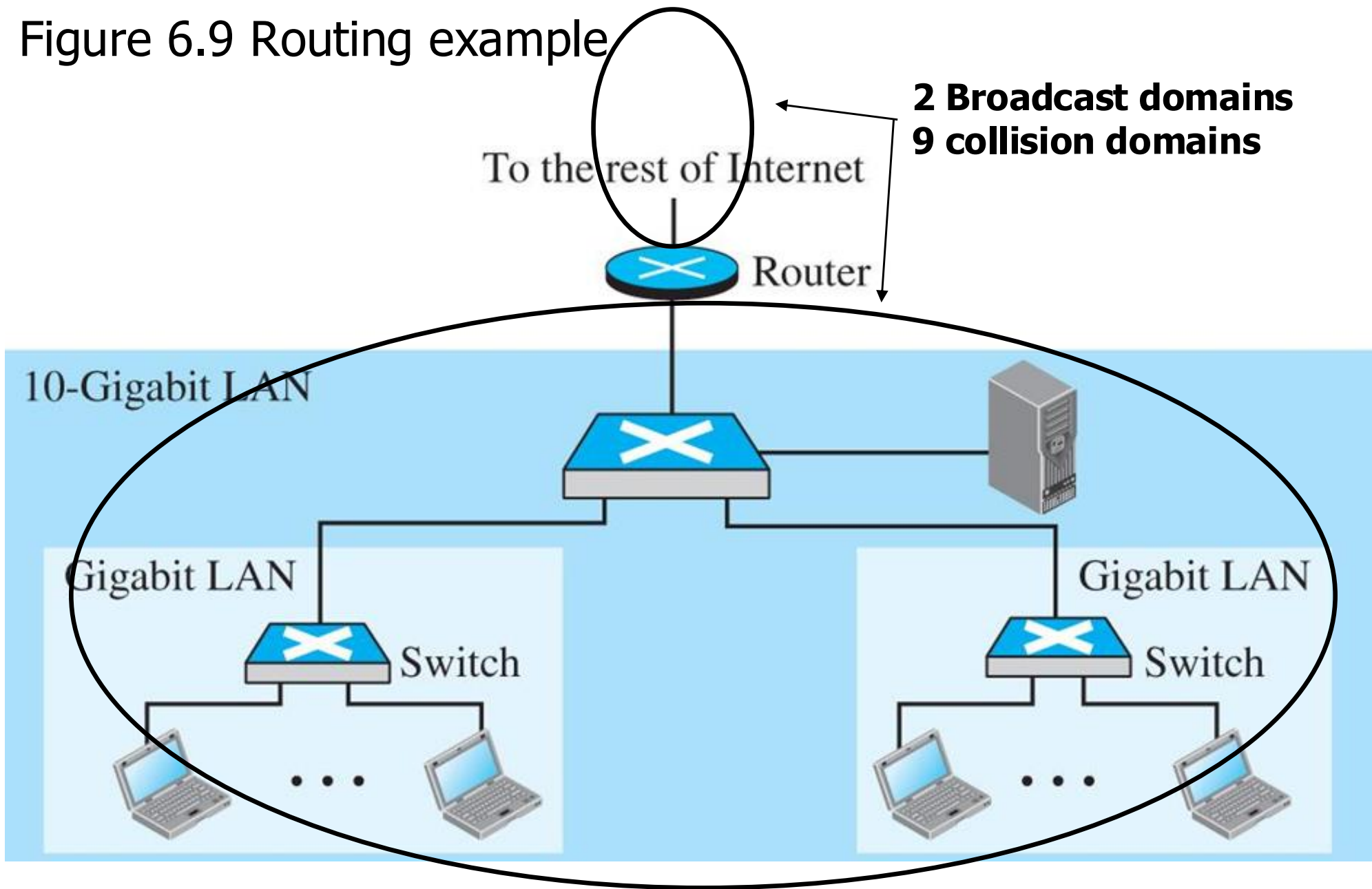
- Can operate in **Full-duplex** mode (can send and receive frames at the same time over the same interface)
- Performs MAC address recognition and frame forwarding in **hardware** (bridge in software)
- *Two types :*
 - **Store-and-forward:** switch receives the whole a frame on the input line, buffers it briefly , performs error checking, then routes it to the appropriate output line (similar to bridge). **Buffering** will cause some **delay**.
 - **Cut-through:** based on the fact that the destination address appears at the beginning of the MAC frame, so once the address is recognized the frame is directly sent to the appropriate output line if the output buffer is empty (no need to buffer it). □ no buffering delay □ **NO ERROR CHECKING**

Routers

- Operates at network layer = deals with **packets** not **frames**
- Connect LANs and WANs with similar or different protocols together
- Each router interface has a physical and IP address
- Routers **isolate both** *collision* domains and *broadcast* domains
- Each router interface is connected to a separate broadcast domain
- Acts like normal stations on a network, but have **more than one** logical address (IP)
- Forward packets based on the destination IP address
- Routers Communicate with each other and exchange routing information
- Determine best route using routing algorithm by special software installed on them
- Forward traffic if information on destination is available otherwise discard it (not like a switch)

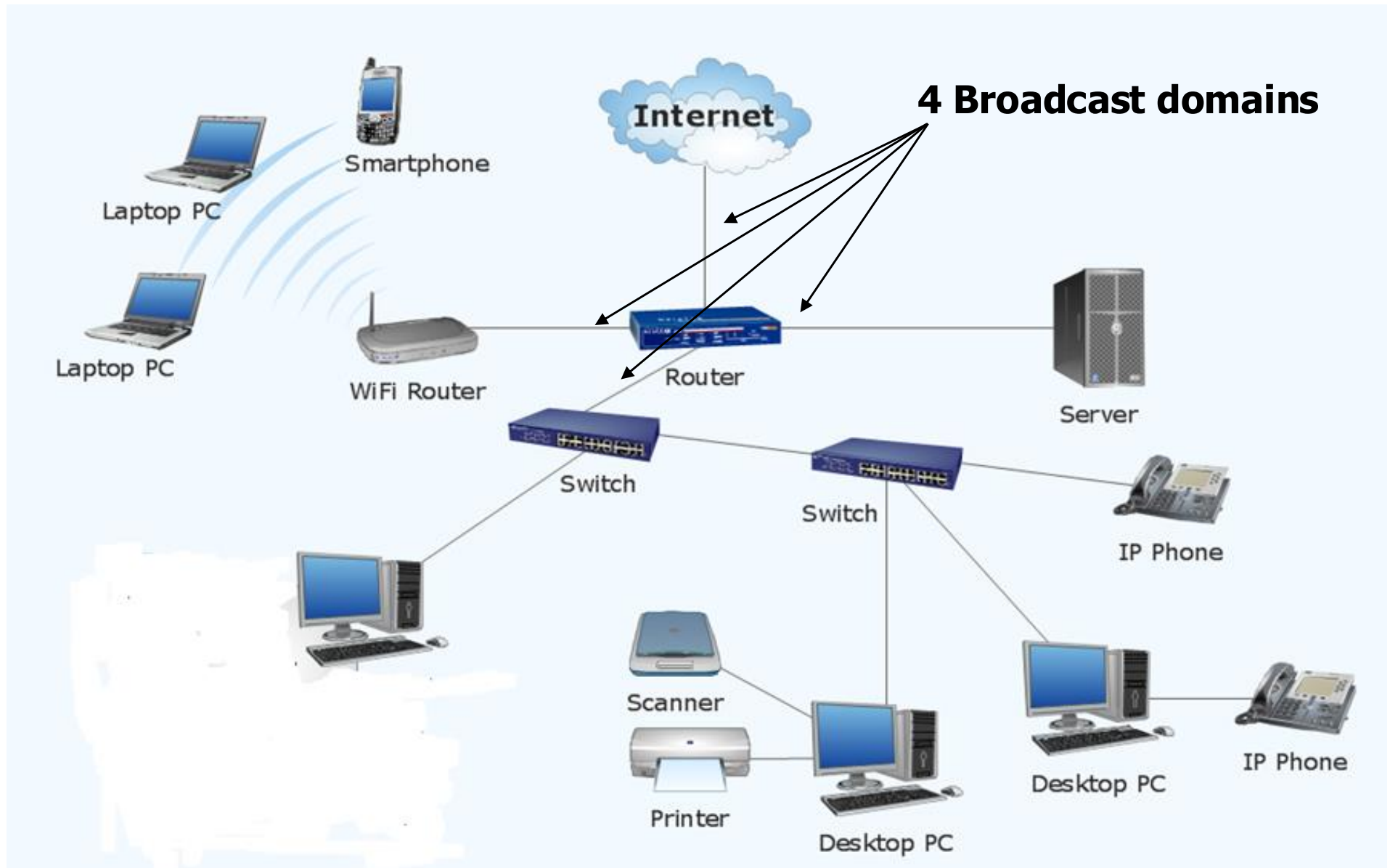


Figure 6.9 Routing example



2 Broadcast domains
9 collision domains

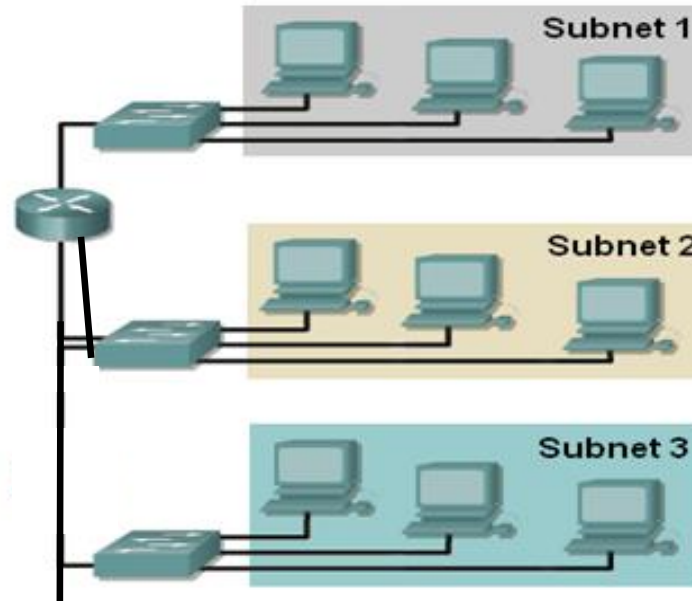
Typical Organization LAN



Comparison between Switch and Router

Router	Switch
Layer 3 Device deals with packets	Layer 2 Device deals with frames
Each Interface has IP address and MAC address	Each Interface has MAC address
Isolates broadcast and Collision Domains	Does not isolate broadcast domains but isolate collision domains.
Drop packet if the destination address is not in the Routing Table	Send frame in all directions if the destination MAC address is not in the MAC address Table
Forward packet based on information in Routing Table	Forward frames based on information in MAC address table.
Needs configuration.	Plug and Play device
Does not apply Cut through	Cut through forwarding

Virtual LANs



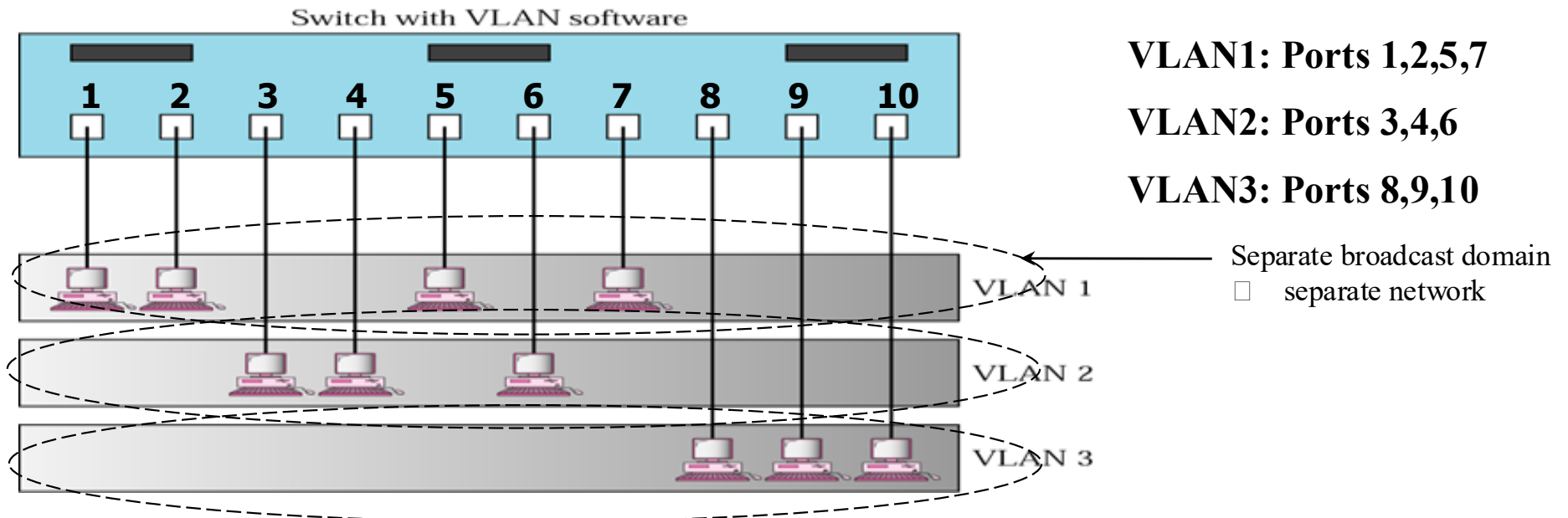
12 Collision domains
3 Broadcast domains

If there is no space in the room to add a user belongs to subnet1, but there is a space in the room where subnet 3 is located. We need to do wiring from the switch in subnet 1 to the room where the user is setting. This is sometimes hard and costly to be done.

What is the alternative solution??

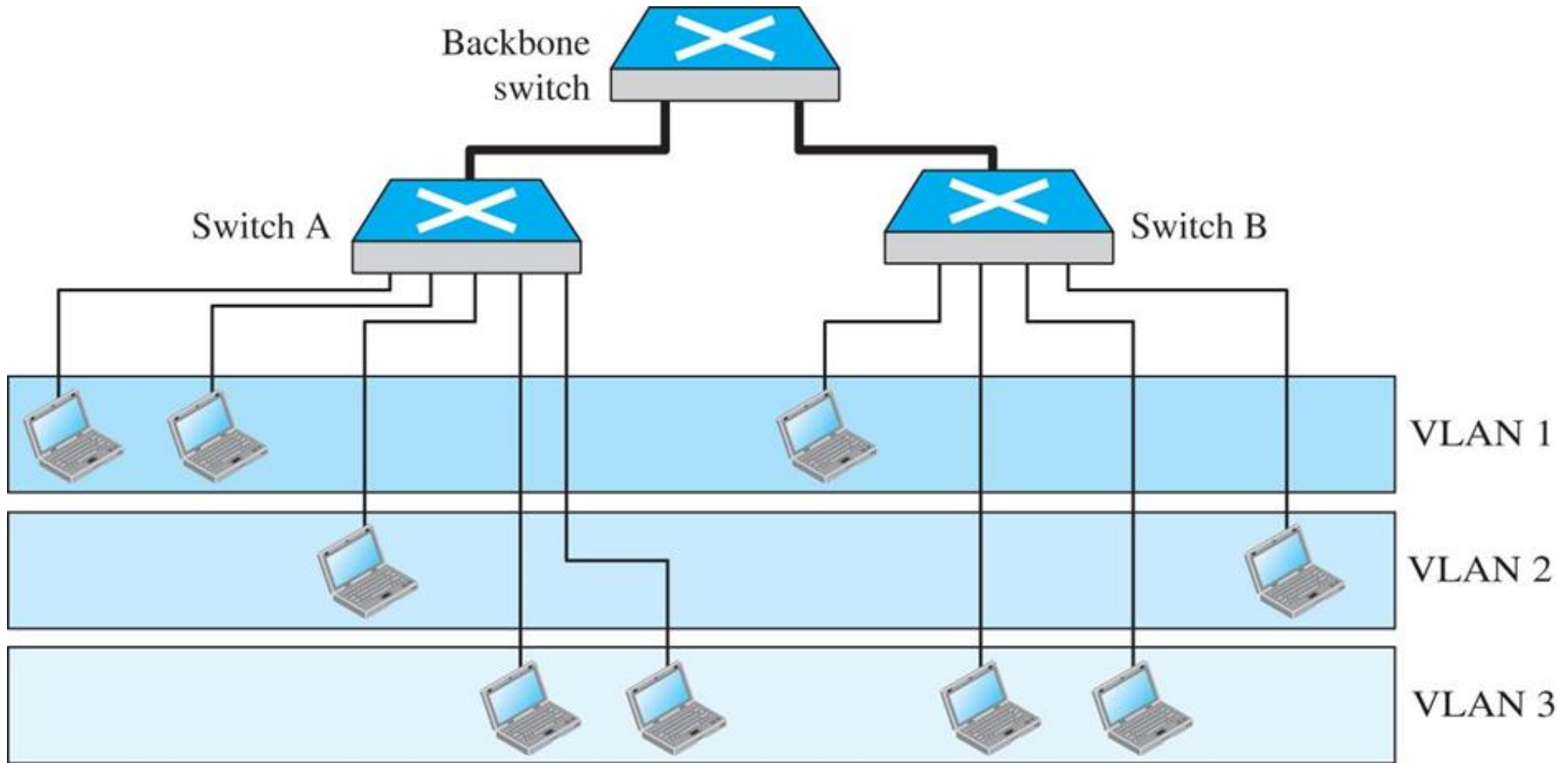
VLAN: Virtual (logical) Local Area Network :
Creating Local Area Network subnets (broadcast domains) by **software** not by physical wiring

Figure A switch using VLAN software



- Using the Virtual LAN technology will allow **grouping** computers **logically** instead of **physically**.
- VLAN divides the physical LAN into several **Logical LANs** called VLANs
- Switch maintains a look up table to know to which LAN a machine belongs to.

Figure 6.12 Two switches in a backbone using VLAN software





VLANs create broadcast domains.

Advantages Of VLAN

- **Reduce cost and installation time:**

- Instead of **physically moving** a station to another segment or another switch, it can be moved by *software*.

- **Increase security:**

- A group of users needing a high security can be put into a VLAN so that NO users outside the VLAN can communicate with them.
- Stations belong to the same group can send **broadcast messages** that will NOT be received by users in others VLAN groups

- **Creating Virtual Workgroups**

- Stations located at physically different locations can be added easily to the same broadcast domain so that they can send broadcast messages to one another.
 - EXAMPLE: people from different departments working on the same project