

# Chapter 10

## Application Layer

- Data Communications and Networking, With TCP/IP protocol suite Sixth Edition
- Behrouz A. Forouzan

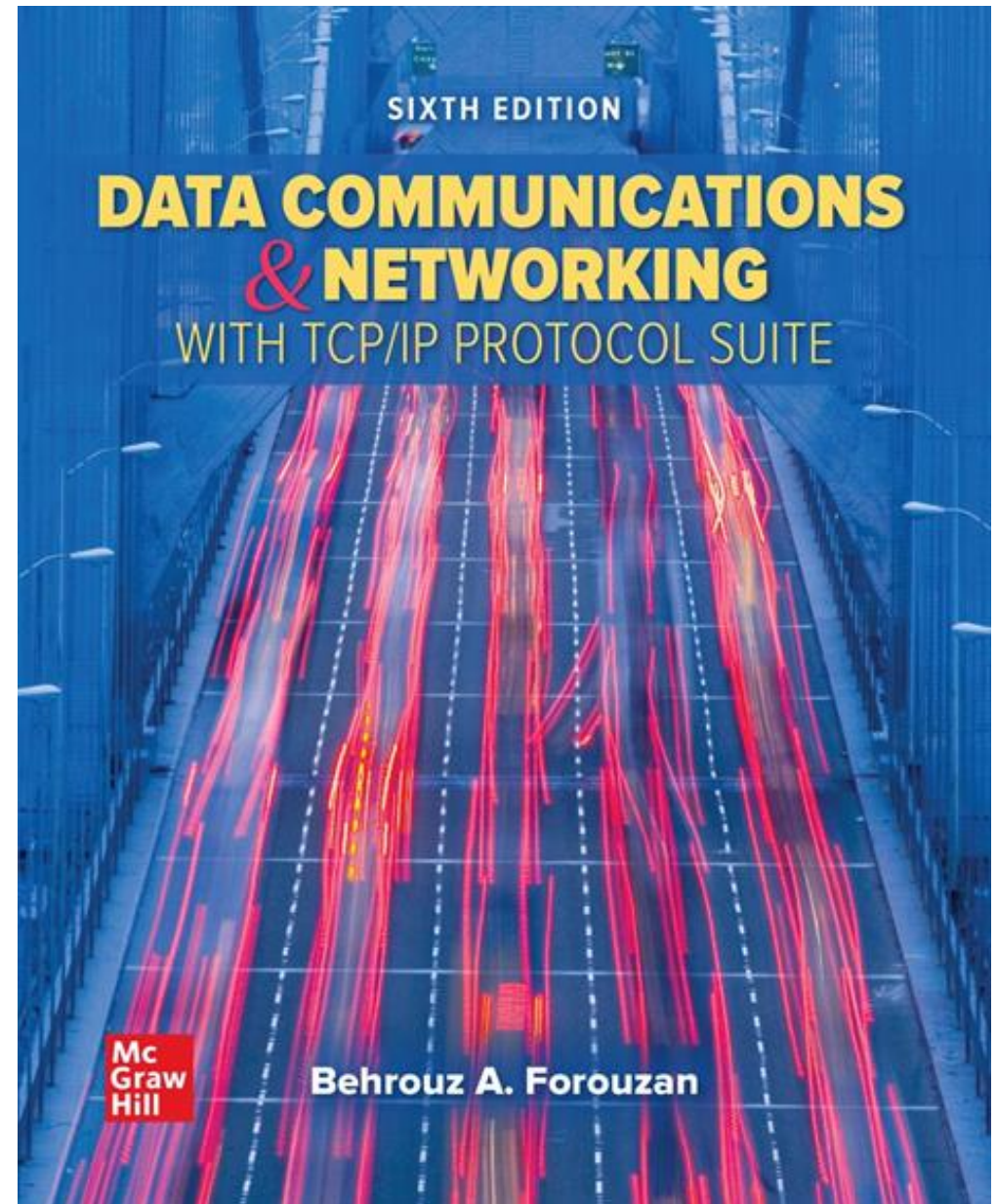

# Domain Name System

- What is DNS?
  - Internet Directory Service
  - A **client-server application** that maps host names into their corresponding IP addresses
  - Mapping host names into their corresponding IP addresses is called name resolution or name translation or name mapping or Address Resolution
- Why we need to use names instead of IP numbers?
  - IP addresses are difficult to remember
- **Problem: Network only understands numeric addresses**
- **Solution:**
  - Use alphanumeric names to refer to hosts
  - Add a **distributed, hierarchical protocol** (called DNS) to map between alphanumeric host names and IP addresses

# Name Space

- **IP addresses are unique** □ **Host names must be unique**
- **How to manage this large number of names?**
- **Solution:**
- Each name is made of several parts (hierarchical). Each part is called a **label**
- Names are defined on **tree** structure with the **root at the top**
  - This is called **hierarchical name space**
- Each node has a **label**
- DNS requires that children of a node (nodes that branch from the same node) have **different labels** to guarantee uniqueness
- This will allow the control of names assignment to be **decentralized**
  - A central authority IANA assigns the part of the name that defines the **nature of the organization (com, net, SA, CA, ...)** and its **name (IEEE, CNN, McGraw, Intel,...)**
  - The rest of the name is **managed by the local organization** (CIS, Eng, sales, ...)

## Table 10.12 Generic domain labels

<i>Label</i>	<i>Description</i>	<i>Label</i>	<i>Description</i>
<b>aero</b>	Airlines and aerospace	<b>int</b>	International organizations
<b>biz</b>	Businesses or firms	<b>mil</b>	Military groups
<b>com</b>	Commercial organizations	<b>museum</b>	Museum
<b>coop</b>	Cooperative organizations	<b>name</b>	Personal names (individuals)
<b>edu</b>	Educational institutions	<b>net</b>	Network support centers
<b>gov</b>	Government institutions	<b>org</b>	Nonprofit organizations
<b>info</b>	Information service providers	<b>pro</b>	Professional organizations

# The DNS Name Space

The Internet is divided into more than **200 top-level domains**

**Domain:** It is subtree of the domain name space and consists of group of hosts that are under the administrative control of a single entity such as a company or a government agency.

Each domain is subdivided into **subdomains**

The leaves represent domains that have no subdomains

A leaf domain may contain a **single host**, or represent a company with thousands of hosts

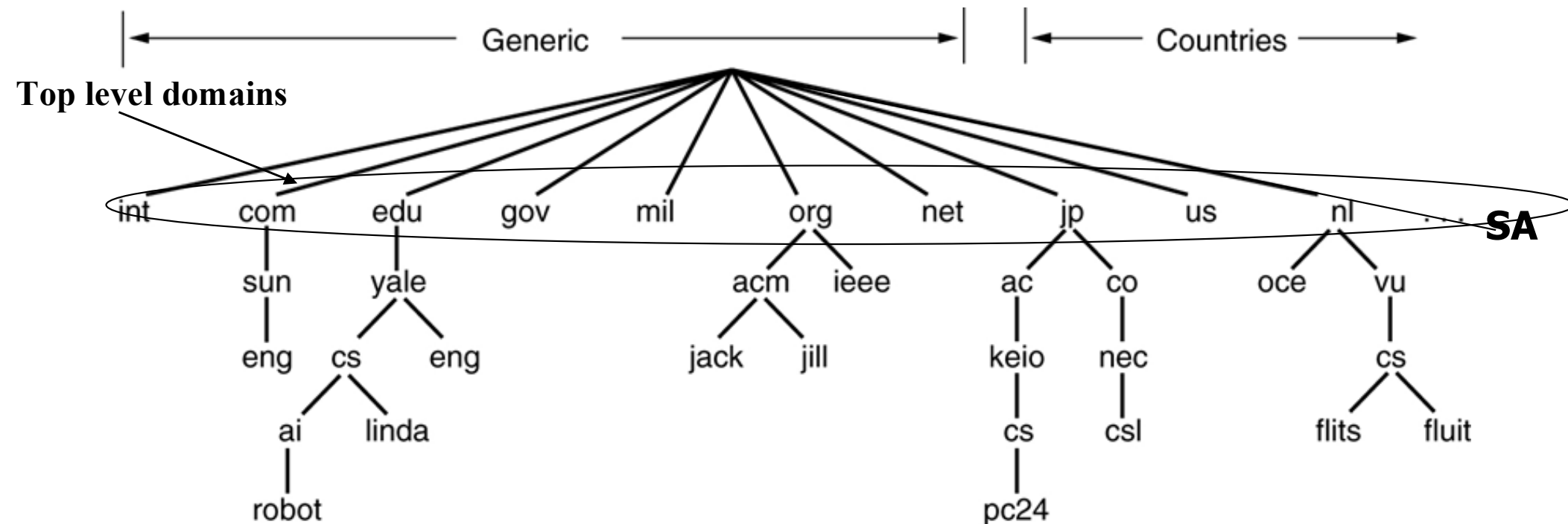

A portion of the Internet **domain name space**.

## Figure 10.38 Domains

- **Domain** is a subtree of domain name space
- Domain is divided into sub-domains
- **Domain name** is the domain name of the node at the top of the subtree

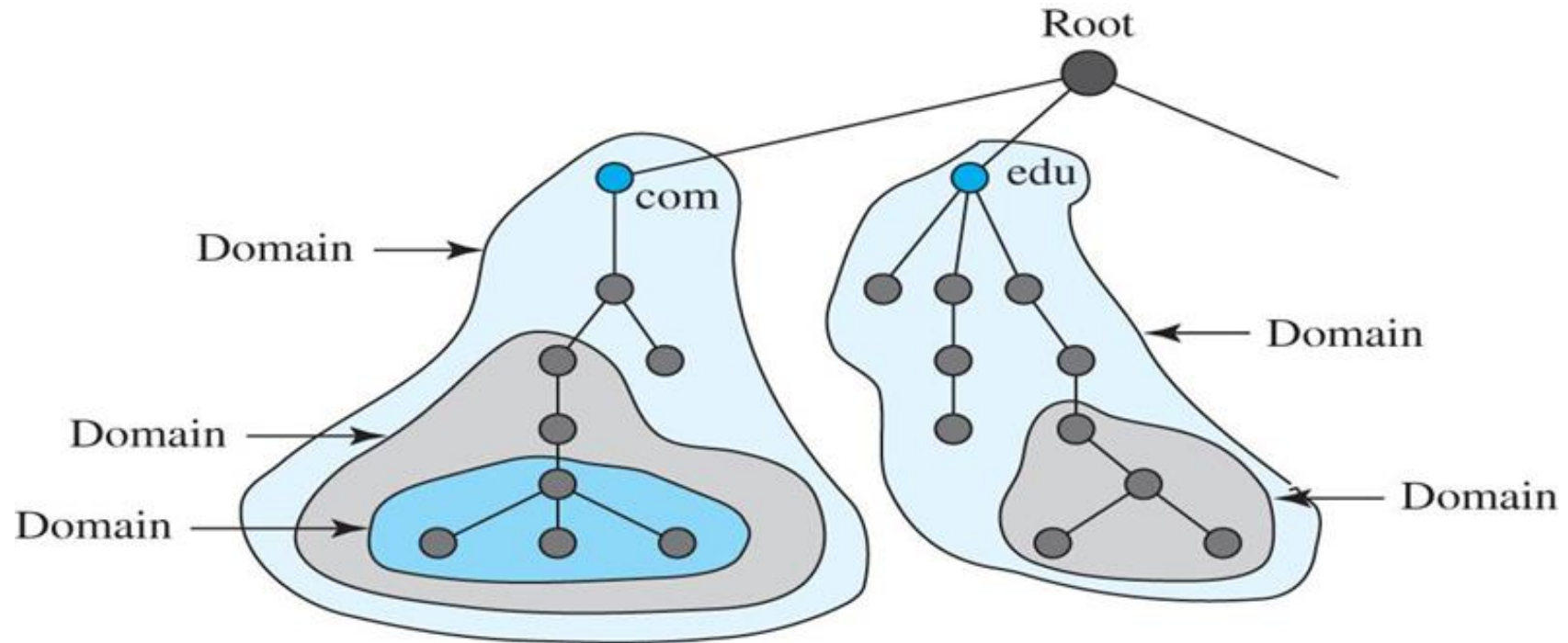
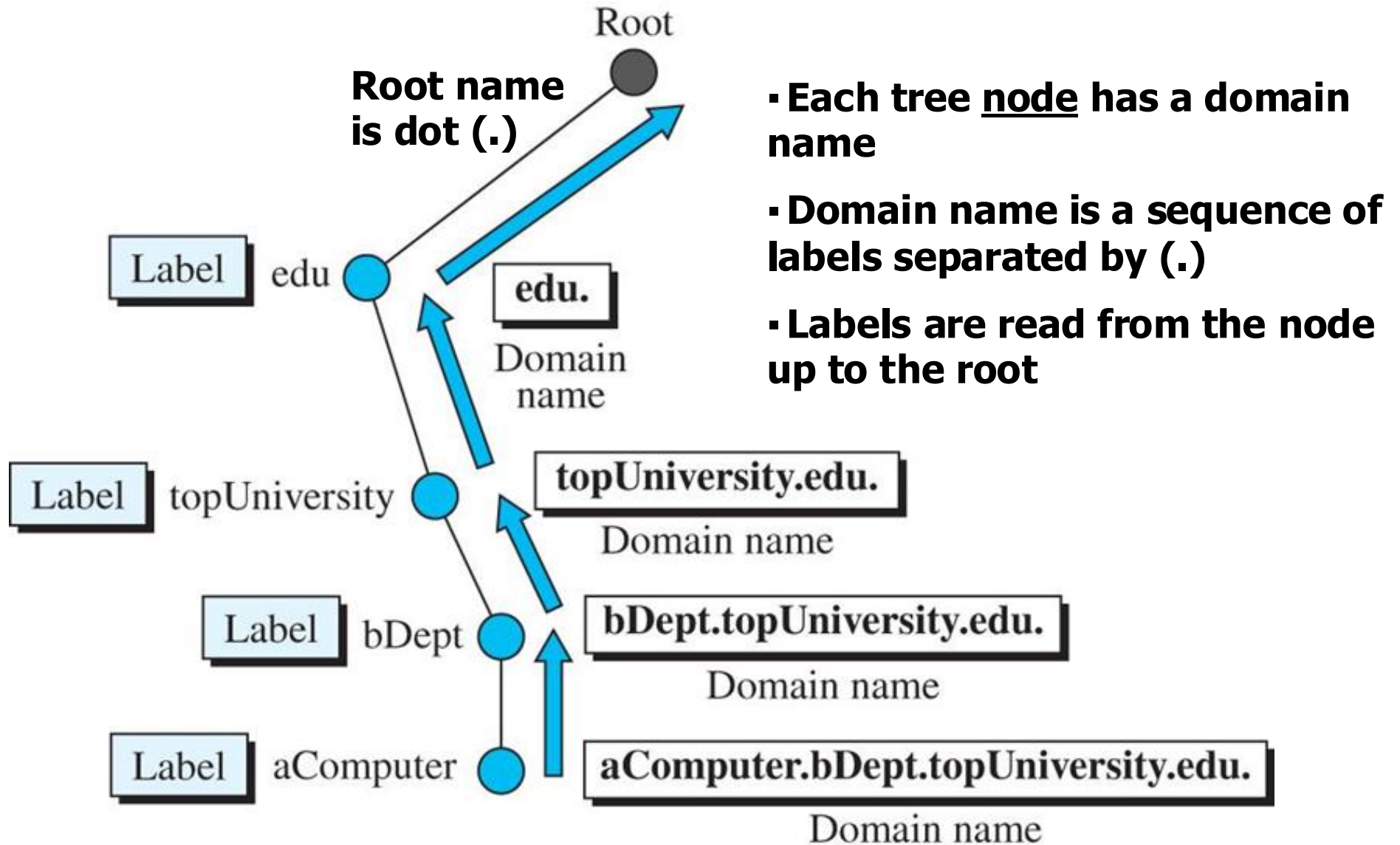

Figure 10.37 Domain names and labels



# FQDN and PQDN

---

FQDN

challenger.atc.fhda.edu.  
cs.hmme.com.  
www.funny.int.

PQDN

challenger.atc.fhda.edu  
cs.hmme  
www

**FQDN= Fully Qualified Domain Name**

**PQDN= Partially Qualified Domain Name (name to be completed)**

**Only FQDN can be translated (Mapped into its IP address)**

**PQDN are used to refer to a name that belongs to the same site. Remaining part (suffix) of the name is completed by the DNS client program (resolver)**

# Distribution of Name Spaces

- The information contained in the domain name space must be stored.
- Where ?
  - Centralized?  inefficient & unreliable why?
    - Heavy traffic because of requests from all over the world
    - Failure makes data not available
    - Hard to maintain
  - DNS is a distributed database system
    - Uses a large number of computers called **name servers**
    - Organized in a hierarchical way and distributed all over the world
    - **No single host** has all the exact mappings for all the hosts in the Internet

Figure 10.39 Hierarchy of name servers

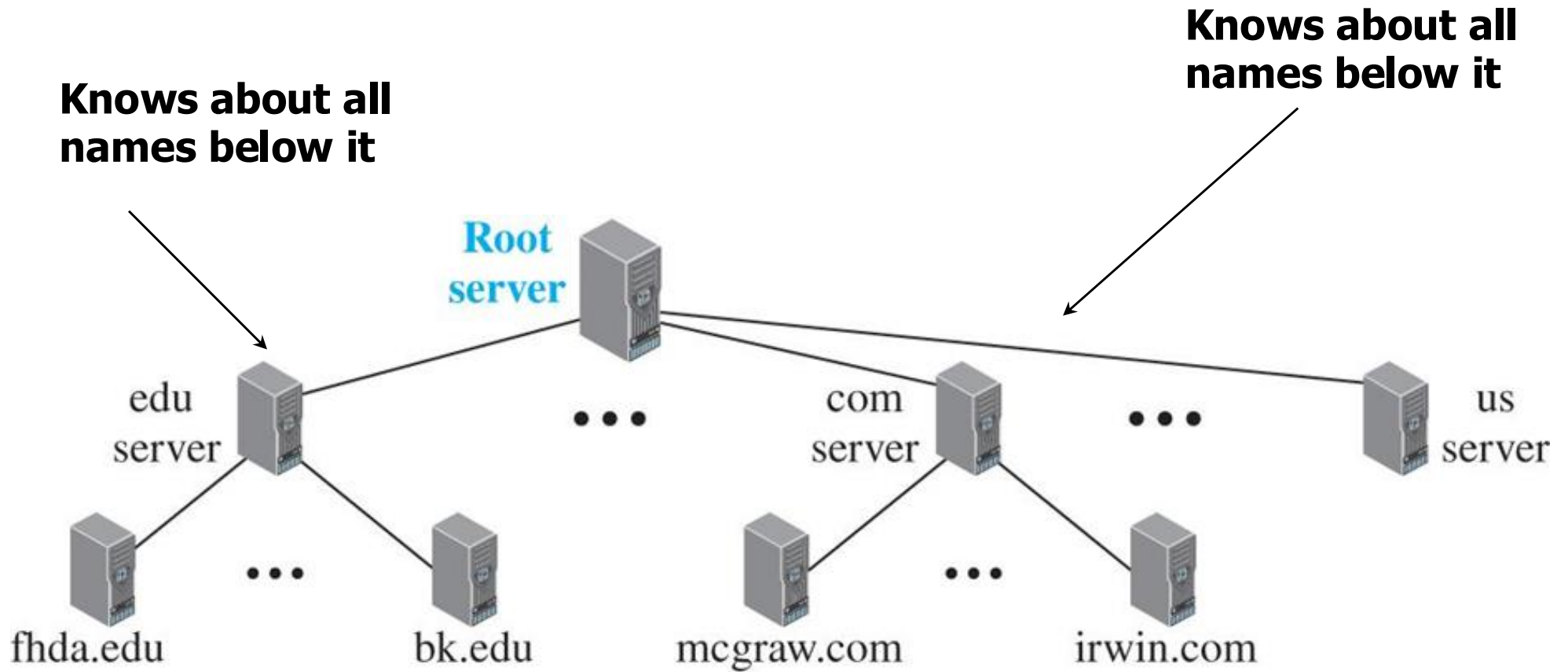



*Note*

**A primary server loads all information from the disk file; the secondary server loads all information from the primary server.**

**When the secondary downloads information from the primary, it is called zone transfer.**

# Root servers

- Root server: a server which has **references for the top level domains**
- **13** root servers distributed all over the world

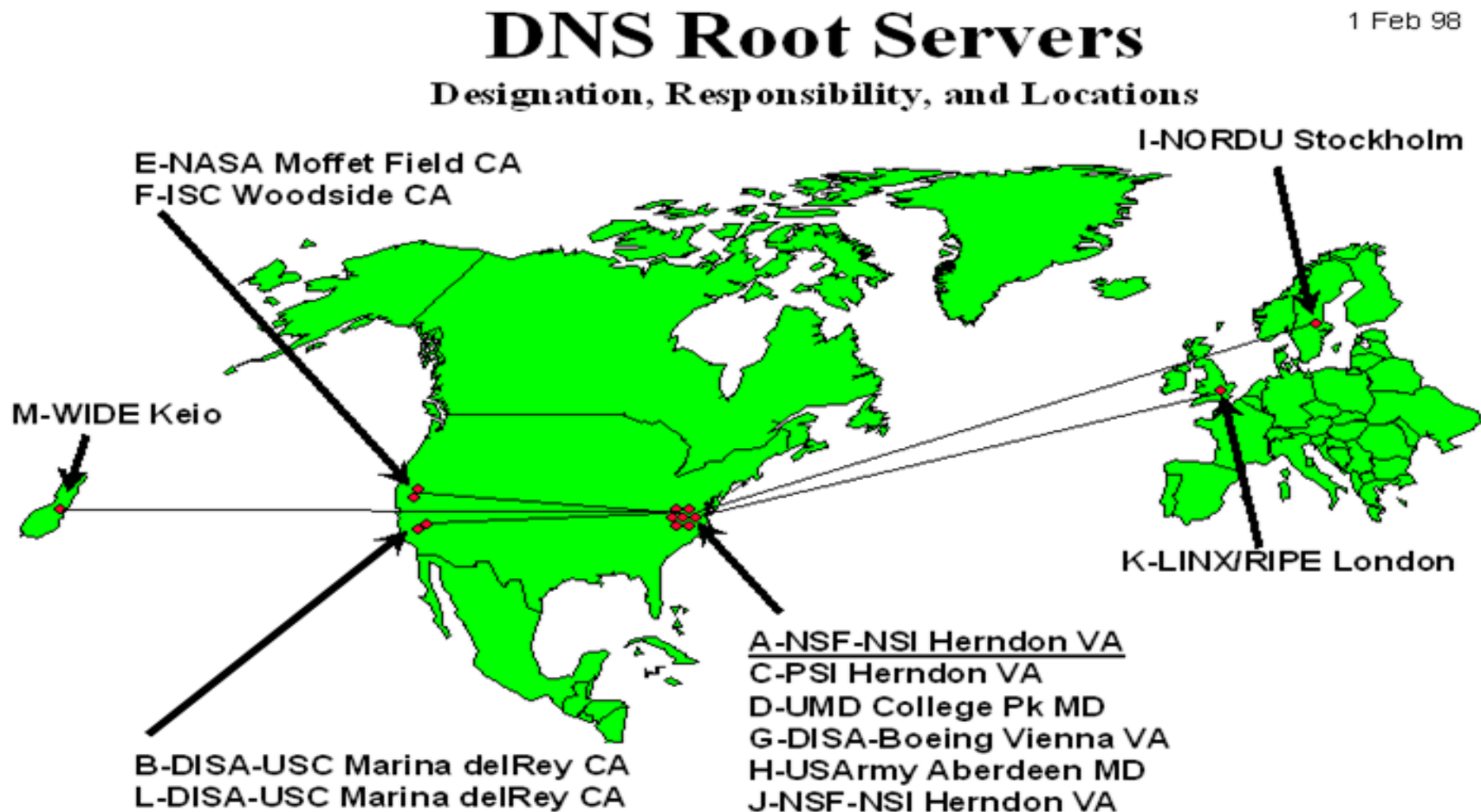

# *DNS Caching*

---

*Each time a server receives a query for a name that is not in its domain, it needs to search its database for a server IP address. Reduction of this search time would increase efficiency. DNS handles this with a mechanism called **caching**.*

# Figure 10.35 Purpose of DNS

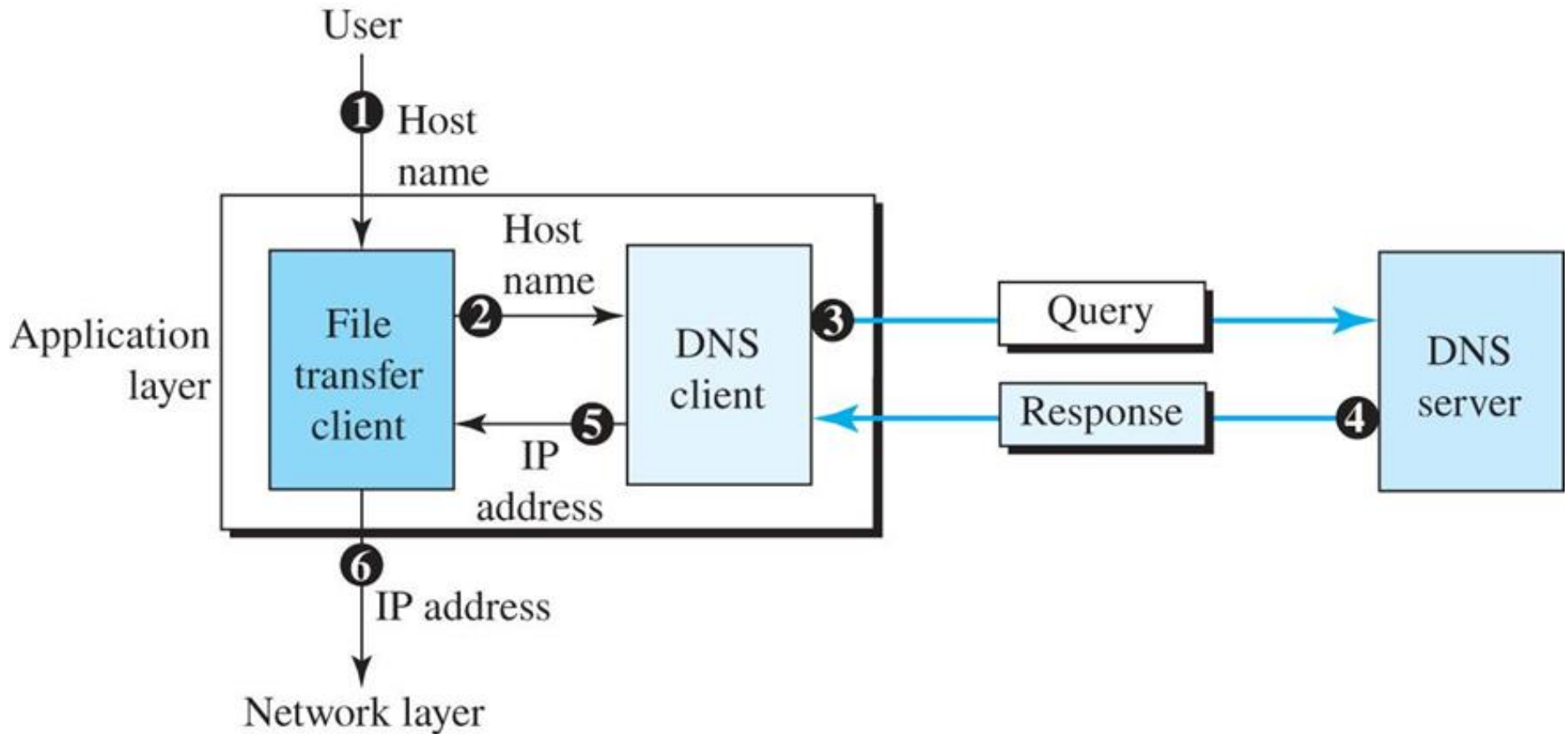

# Name resolution

- **DNS is a client-server application**
  - Client part is called **name resolver**
  - Server part is called **Name server** – **Its host name starts by DNS label**
- **Steps of resolver operations:**
  - A resolver receives a request from application layer (for example http) in the form of a system call, and
  - Returns the desired information in a form compatible with the local host's data formats.
- Two techniques to map the host name to its IP address

## 1- Recursive resolution :

- Host **A** queries the site **local name server B**
- If **B** has the answer in its cache or in its database, it returns it to **A**, **otherwise** it send requests to one of the **root name servers**
- The **root name** server (if it does not have the answer in its cache or in its database) sends request to another name server in the **next level** of the tree say ( **C** )
- The process is repeated until an answer is obtained
- Then, the answer will be transmitted back until it finally reaches the requesting host (**A**)
- See the next example

# 1- Recursive resolution (mapping) - Example

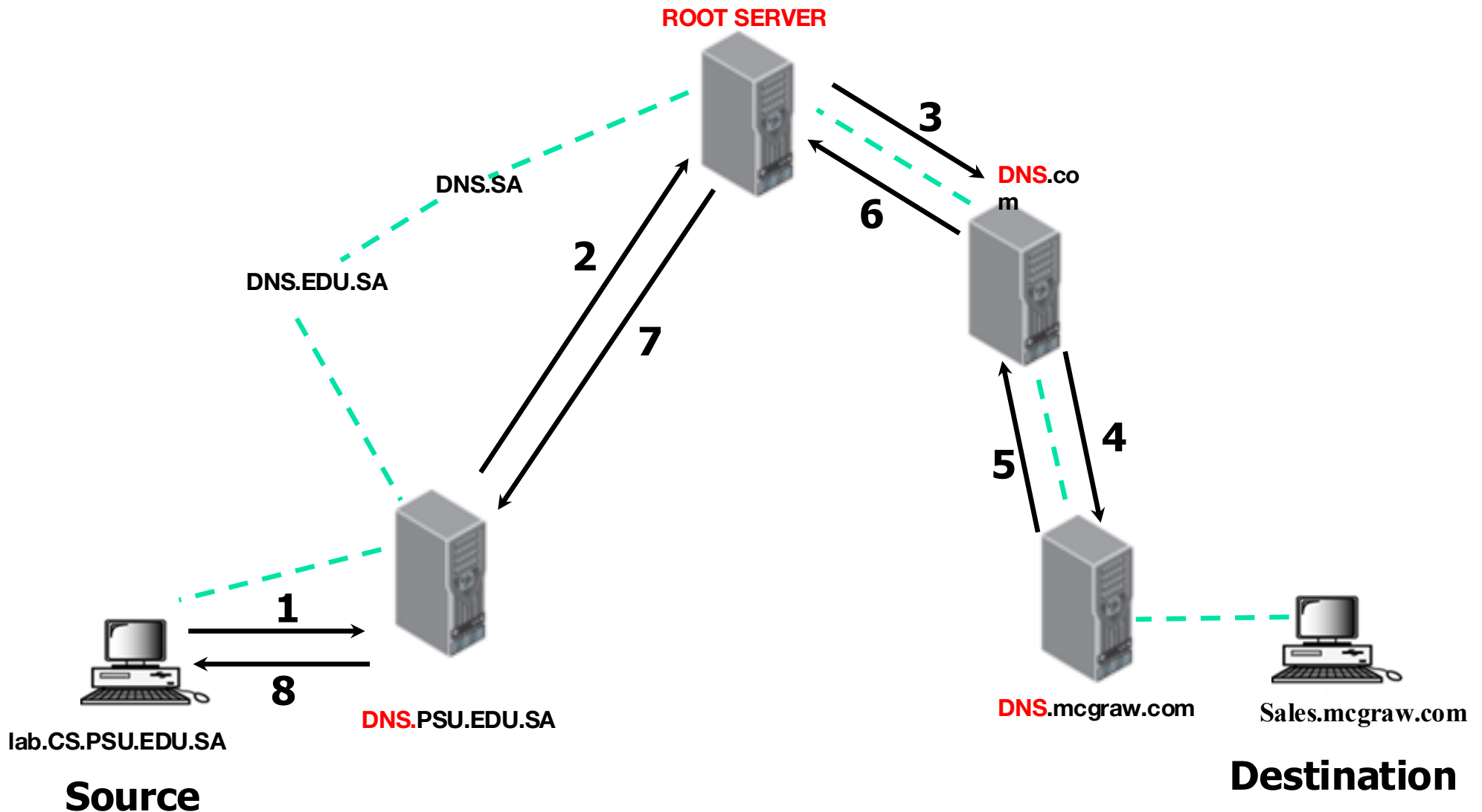

In this example the source (`lab.CS.PSU.EDU.SA`) contacted web server (`Sales.mcgraw.com`)

# 1- Recursive resolution – Example (cont'd.)

In the previous example, the mapping will be done as follows:

- 1- Host lab.CS.PSU.EDU.SA contacts the **local name server** (DNS.PSU.EDU.SA) to query for the IP address of web server **sales.McGraw.com**
- 2- If (DNS.PSU.EDU.SA) does not have the answer in its cache or in its database, it will contact **the root name server** to query for the IP address of web server sales.McGraw.com
- 3- If the root name server does not have the answer in its cache or in its database, it will contact the name server responsible for the .com domain (DNS.com ) to query for the IP address of web server sales.McGraw.com
- 4- If (DNS.com) does not have the answer in its cache or in its database, it will contact (DNS.McGraw.com) which has the IP address for web server (Sales.McGraw.com)
- 5- (DNS.McGraw.com) will return the answer to (DNS.com)
- 6- (DNS.com) will return the answer to the root name server
- 7- The root name server will return the answer to (DNS.PSU.EDU.SA)
- 8- DNS.PSU.EDU.SA will return the answer to Host lab.CS.PSU.EDU.SA

## 2- Iterative resolution (mapping)

- Host **A** sends a query to **local name server B**
- If **B** has the answer in its cache or in its database, it returns it to **A**, **otherwise it send requests to one of the root name servers**
- The root name server (if it does not have the answer in its cache or in its database) sends a reply to **B** that contains the **IP address** of name server in the **next level of the tree** say ( **C** )
- **Local name server B** then sends a query directly to name server **C**
- The process is repeated until **local name server B** received the **IP address** for the requested mapping
- **Local name server B** then sends the answer to Host **A**
- SEE the next example

## 2- Iterative resolution - Example

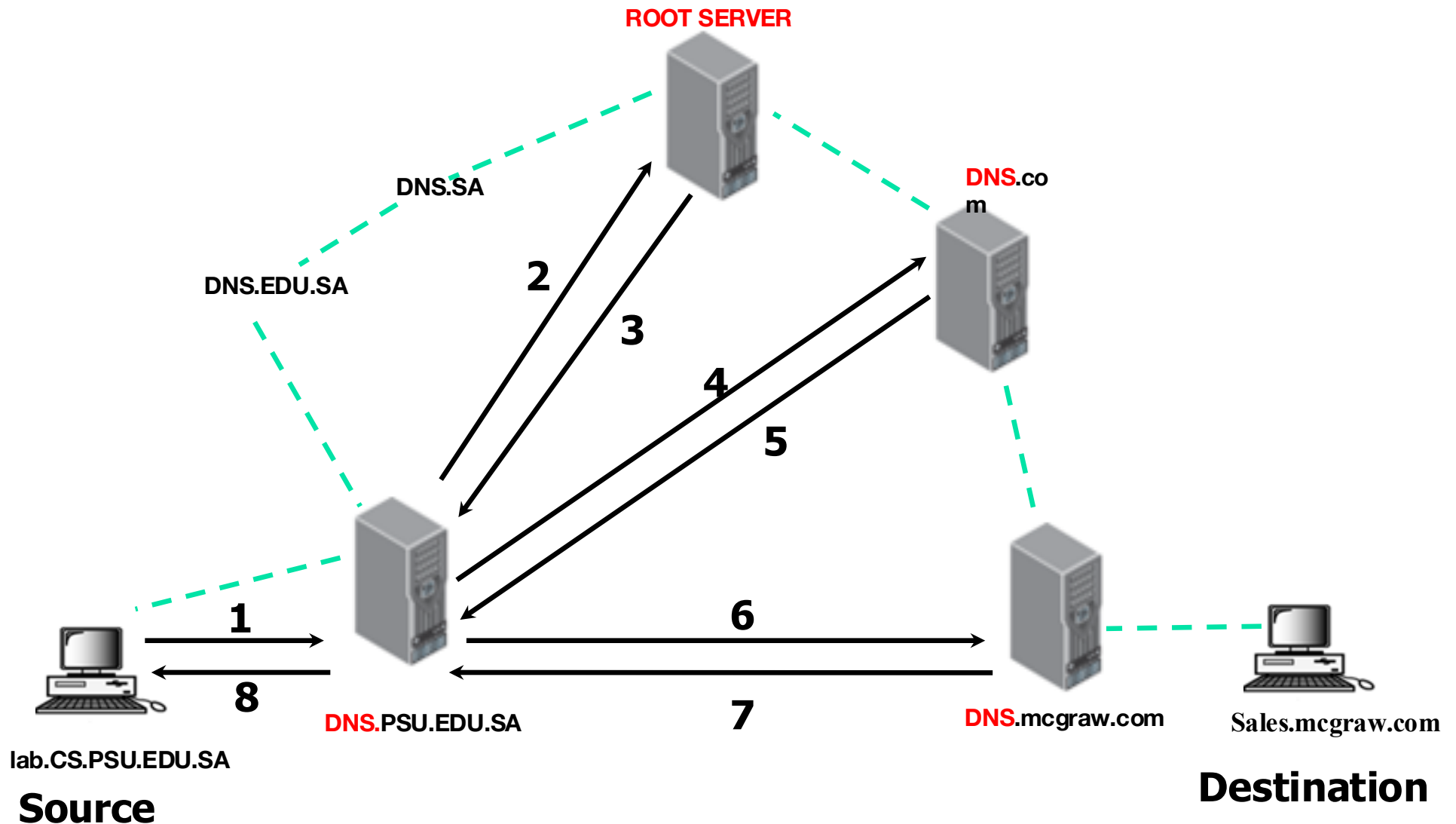

In this example the source (`lab.CS.PSU.EDU.SA`) contacted web server (`Sales.mcgraw.com`)

## 2- Iterative resolution – Example (cont'd.)

**In the previous example, the mapping will be done as follows:**

- 1- Host lab.CS.PSU.EDU.SA contacts the **local name server** (DNS.PSU.EDU.SA) to query for the IP address of web server **sales.McGraw.com**
- 2- If (DNS.PSU.EDU.SA) does not have the answer in its cache or in its database, it will contact **the root name server** to query for the IP address of web server sales.McGraw.com
- 3- If the root name server does not have the answer in its cache or in its database, it will reply to the local name server (DNS.PSU.EDU.SA) with the IP address of the name server for the (.com) domain which is (DNS.com)
- 4- The local name server (DNS.PSU.EDU.SA) will contact the name server (DNS.com) to query for the IP address of web server sales.McGraw.com
- 5- If (DNS.com) does not have the answer in its cache or in its database, it will reply to the local name server (DNS.PSU.EDU.SA) with the IP address of the name server DNS.McGraw.com which is the local name server for domain McGraw.com
- 6- The local name server (DNS.PSU.EDU.SA) will contact the name server (DNS.McGraw.com) to query for the IP address of web server sales.McGraw.com
- 7- Since name server DNS.McGraw.com is the local name server for McGraw.com domain it will reply to the local name server (DNS.PSU.EDU.SA) with the IP address for web server sales.McGraw.com
- 8- The local name server (DNS.PSU.EDU.SA) will reply to Host lab.CS.PSU.EDU.SA with the IP address for web server sales.McGraw.com



---

*Note*

**DNS can use the services of UDP or TCP using the well-known port 53.**